

# \*TB 9-5985-314-35

DEPARTMENT OF THE ARMY TECHNICAL BULLETIN

## CALIBRATION PROCEDURE FOR DIRECTIONAL COUPLERS, VSWR BRIDGES, COAXIAL CIRCULATORS, POWER SPLITTERS, AND POWER DIVIDERS (10 MHZ TO 40 GHZ) (GENERAL)

Headquarters, Department of the Army, Washington, DC  
25 April 2006

*Distribution Statement A: Approved for public release; distribution is unlimited.*

### REPORTING OF ERRORS AND RECOMMENDING IMPROVEMENTS

You can improve this manual. If you find any mistakes or if you know of a way to improve these procedures, please let us know. Mail your letter or DA Form 2028 (Recommended Changes to Publications and Blank Forms) directly to Commander, US Army Aviation and Missile Command, AMSAM-MMC-MA-NP, Redstone Arsenal, AL 35898-5000. A reply will be furnished to you. You may also provide DA Form 2028 information to AMCOM via e-mail, fax, or the World Wide Web. Our FAX number is: DSN 788-6546 or Commercial 256-842-6546. Our e-mail address is: [2028@redstone.army.mil](mailto:2028@redstone.army.mil). Instructions for sending an electronic 2028 may be found at the back of this manual. For the World Wide Web, use: <https://amcom2028.redstone.army.mil>.

SECTION		Paragraph	Page
I.	IDENTIFICATION AND DESCRIPTION		
	Test instrument identification .....	1	3
	Forms, records, and reports.....	2	3
	Calibration description .....	3	3
II.	EQUIPMENT REQUIREMENTS		
	Equipment required.....	4	3
	Accessories required.....	5	3
III.	CALIBRATION PROCESS FOR DIRECTIONAL COUPLERS		
	Preliminary instructions.....	6	5
	Definitions .....	7	6
	Equipment setup .....	8	6
	Coupling and directivity tests .....	9	7
	Final procedure .....	10	15

\*This bulletin supersedes TB 9-5985-314-35, dated 24 December 1996, including all changes.

		Paragraph	Page
	IV. CALIBRATION PROCESS FOR VSWR BRIDGES		
	Preliminary instructions.....	11	15
	Equipment setup .....	12	15
	Directivity .....	13	15
	Final procedure .....	14	18
SECTION	V. CALIBRATION PROCESS FOR COAXIAL CIRCULATORS		
	Preliminary instructions.....	15	18
	Definitions .....	16	18
	Equipment setup .....	17	18
	Insertion loss and isolation.....	18	19
	Final procedure .....	19	21
	VI. CALIBRATION PROCESS FOR POWER SPLITTERS AND POWER DIVIDERS		
	Preliminary instructions.....	20	21
	Equipment setup .....	21	21
	Insertion loss and output port tracking.....	22	23
	Final procedure .....	23	31
APPENDIX	A. DIRECTIONAL COUPLERS TEST INSTRUMENT IDENTIFICATION .....		A-1
APPENDIX	B. VSWR BRIDGES TEST INSTRUMENT IDENTIFICATION .....		B-1
APPENDIX	C. THREE PORT CIRCULATOR TEST INSTRUMENT IDENTIFICATION .....		C-1
APPENDIX	D. POWER SPLITTERS AND POWER DIVIDERS TEST INSTRUMENT IDENTIFICATION .....		D-1
APPENDIX	E. ALTERNATE CALIBRATION PROCESS FOR DIRECTIONAL COUPLERS (10MHz to 18GHz) .....		E-1
APPENDIX	F. ALTERNATE CALIBRATION PROCESS FOR VSWR BRIDGES (10MHz TO 18GHz) .....		F-1
APPENDIX	G. ALTERNATE CALIBRATION PROCESS FOR COAXIAL CIRCULATORS (10MHz TO 18GHz) .....		G-1
APPENDIX	H. ALTERNATE CALIBRATION PROCESS FOR POWER SPLITTERS AND POWER DIVIDERS (10MHz TO 18GHz).....		H-1

## SECTION I IDENTIFICATION AND DESCRIPTION

**1. Test Instrument Identification.** This bulletin provides instructions for the calibration of Directional Couplers, VSWR Bridges, Coaxial Circulators, Power Splitters, and Power Dividers (10 MHz to 40 GHz) (General). The manufacturers' manuals were used as the prime data sources in compiling these instructions. The equipment being calibrated will be referred to as the TI (test instrument) throughout this bulletin.

**a. Model Variations.** Variations among models are described in Appendices A, B, C, and D.

**b. Time and Technique.** The time required for this calibration is approximately 7 hours, using the microwave technique.

### **2. Forms, Records, and Reports**

**a.** Forms records, and reports required for calibration personnel at all levels are prescribed by TB 750-25.

**b.** Adjustments to be reported are designated (R) at the end of the sentence in which they appear. When adjustments are in tables, the (R) follows the designated adjustment. Report only those adjustments made and designated with (R).

**3. Calibration Description.** TI identification, including manufacturer, model number, parameters, and performance specifications which pertain to this calibration are listed in Appendices A, B, C, and D. TIs other than those listed in appendices may be certified with the techniques in this procedure if the manufacturers' manuals are available.

## SECTION II EQUIPMENT REQUIREMENTS

**4. Equipment Required.** Table 1 identifies the specific equipment to be used in this calibration procedure. This equipment is issued with Secondary Transfer Calibration Standards Set AN/GSM-287 and Secondary Reference Calibration Standards Set NSN 4931-00-621-7878. Alternate items may be used by the calibrating activity. The items selected must be verified to perform satisfactorily prior to use and must bear evidence of current calibration. The equipment must meet or exceed the minimum use specifications listed in table 1. The accuracies listed in table 1 provide a four-to-one ratio between the standard and TI.

**5. Accessories Required.** The accessories required for this calibration are common usage accessories, issued as indicated in paragraph 4 above, and are not listed in this calibration procedure. The following peculiar accessories are also required for this calibration: N-short, Hewlett-Packard, Model 11512A (11512A) and U301 termination (18-40GHz).

**TB 9-5985-314-35**

Table 1. Minimum Specifications of Equipment Required

Common name	Minimum use specifications	Manufacturer and model (part number)
ATTENUATOR (FIXED)	Range: 30 dB Frequency range: 10 MHz to 18 GHz Accuracy: $\pm 1.0$ dB Range: 60 dB Frequency range: 10 MHz to 18 GHz Accuracy: $\pm 1.5$ dB	Weinschel, Models 9918-30dB and 9918-60dB
FREQUENCY EXTENSION KIT NO. 1	Frequency range: 18.0 to 26.5 GHz IF frequency: 700 MHz Combined accuracy with receiver system: $\pm 0.03$ dB/10 dB	Weinschel, Model 1611)
FREQUENCY EXTENSION KIT NO. 2	Frequency range: 26.5 to 40 GHz IF frequency: 1 GHz Combined accuracy with receiver system: $\pm 0.03$ dB/10 dB	Weinschel, Model 1612
MISMATCH STANDARDS	Frequency range: 0.01 to 18 GHz VSWR: <sup>1</sup> 1.05 $\pm$ .00, -.05 (0.01 to 4 GHz) $\pm$ .05 (4 to 18 GHz) 1.2 $\pm$ .10 1.50 $\pm$ .17 2.00 $\pm$ .22 Frequency range: 18 to 26.5 GHz 1.105 $\pm$ 0.0035 <sup>2</sup> 1.5 $\pm$ 0.0073 <sup>2</sup> Frequency range: 26.5 to 40 GHz 1.105 $\pm$ 0.004 <sup>2</sup> 1.5 $\pm$ 0.007 <sup>2</sup>	Premier Microwave 2334-001-1  2334-001-2 2334-001-3 2334-001-4  PRD Electronics 7913200-3-2 Micro Lab 7913200-3-5  PRD Electronics 7913200-4-2 Micro Lab 7913200-4-5
POWER METER	Frequency range: 10 MHz to 18 GHz  Power range: 0 to -70 dBm  Accuracy: $\pm$ dB/10 dB	Hewlett-Packard, Model 437B (13440045) with power sensor, Hewlett-Packard, Model 8482A (13440043), and power sensor, Hewlett-Packard, Model 8485D with 30 dB attenuator, Hewlett-Packard, Model 11708A
POWER SPLITTER	Frequency range: 10 MHz to 18 GHz Insertion loss: -6 dB -0.2 +1.5 dB Output tracking between ports: 10 MHz to 2 GHz: $\pm$ 0.15 dB 2 to 8 GHz: $\pm$ 0.2 dB 8 to 18 GHz: $\pm$ 0.25 dB	Weinschel, Model 1870A (7916839)
RECEIVER SYSTEM	Frequency range: 10 MHz to 18 GHz Attenuation range: 0.00 to 48 dB Accuracy: $\pm$ 0.02 dB/10 dB	Weinschel, Model VM4A

See footnotes at end of table.

Table 1. Minimum Specifications of Equipment Required - Continued

Common name	Minimum use specifications	Manufacturer and model (part number)
SIGNAL GENERATOR NO. 1	Frequency range: 0.01 to 40 GHz <sup>3</sup> Power output: +8 dBm, ±1dB Flatness: 10 to 50 MHz: ±2 dB .05 to 18 GHz: ±0.8 dB	Wiltron/Anritsu, Model 68369NV
SIGNAL GENERATOR NO. 2	Frequency range: 0.01 to 18 GHz  Power output: +11 dBm, ±1dB  Flatness: 10 to 50 MHz: ±2 dB  .05 to 18 GHz: ±0.8 dB	Wiltron/Anritsu, Model 68347M
TERMINATION <sup>4</sup>	Frequency range: 8.2 to 12.4 GHz VSWR: 1.015 (max) Impedance: 50 Ω  Frequency range: 12.4 to 18 GHz VSWR: 1.02 (max) Impedance: 50 Ω  Frequency range: 18 to 40 GHz VSWR: <sup>1</sup> Impedance: 50 Ω  Frequency range: DC to 18 GHz VSWR: <sup>1</sup>	Hewlett-Packard, Model X910B (X910B)  Hewlett-Packard, Model P910A (P910A)  Maury Microwave, Model U301 (U301)  Maury Microwave, Model 2334-001-1 (2334-001-1)

<sup>1</sup>As charted on calibration report provided by Primary Lab (for secondary reference only).

<sup>2</sup>Reflection coefficient.

<sup>3</sup>Not calibrated above 18GHz.

<sup>4</sup>Select as required: Two each may be required.

### SECTION III CALIBRATION PROCESS FOR DIRECTIONAL COUPLERS

#### 6. Preliminary Instructions

a. The instructions outlined in paragraphs 6 through 8 are preparatory to the calibration process. Personnel should become familiar with the entire bulletin before beginning the calibration.

b. Items of equipment used in this procedure are referenced within the text by common name as listed in table 1.

## TB 9-5985-314-35

c. Unless otherwise specified, verify the result of each test and, whenever the test requirement is not met, take corrective action before continuing with the calibration. Omit steps for parameters listed in Appendix A with the statement N/A.

**7. Definitions.** Explanation of terms peculiar to directional couplers are listed in **a** through **d** below to ensure accurate interpretation of the measurement techniques used in this procedure.

**a. Nominal Coupling.** The nominal loss between the primary input port and the auxiliary side arm port, with the output port terminated, is called coupling. Normally coupling is expressed in dB.

**b. Coupling Variation.** The maximum average deviation from the coupling value resulting from manufacturing process, is called coupling variation and is normally expressed in dB.

**c. Frequency Sensitivity.** The allowable deviation from the average coupling value (coupling variation), resulting from the frequency characteristics of a directional coupler, is called frequency sensitivity and is normally expressed in dB.

**d. Directivity.** The difference between the coupling value (in dB) and the insertion loss (isolation) (in dB) measured between the output port and side arm port (reverse direction) with the input port terminated is called directivity and is expressed in dB.

## 8. Equipment Setup

**a.** Use Appendix A to determine TI parameters as listed in (1) through (5) below:

- (1) Frequency range.
- (2) Coupling value.
- (3) Coupling variation.
- (4) Frequency sensitivity.
- (5) Directivity.

**b.** Select appropriate equipment setup for TI frequency range from figures as listed in (1) through (3) below:

- (1) 10 MHz to 18 GHz, figure 1.
- (2) 18 to 26.5 GHz, figure 2.
- (3) 26.5 to 40 GHz, figure 3.

**c.** Determine and record a minimum of 10 evenly spaced test frequencies over the TI entire frequency range.

**d.** Connect equipment as shown in figures 1, 2, or 3 and allow 1 hour for equipment warm-up for figure 1 (3 hours for figures 2 and 3).

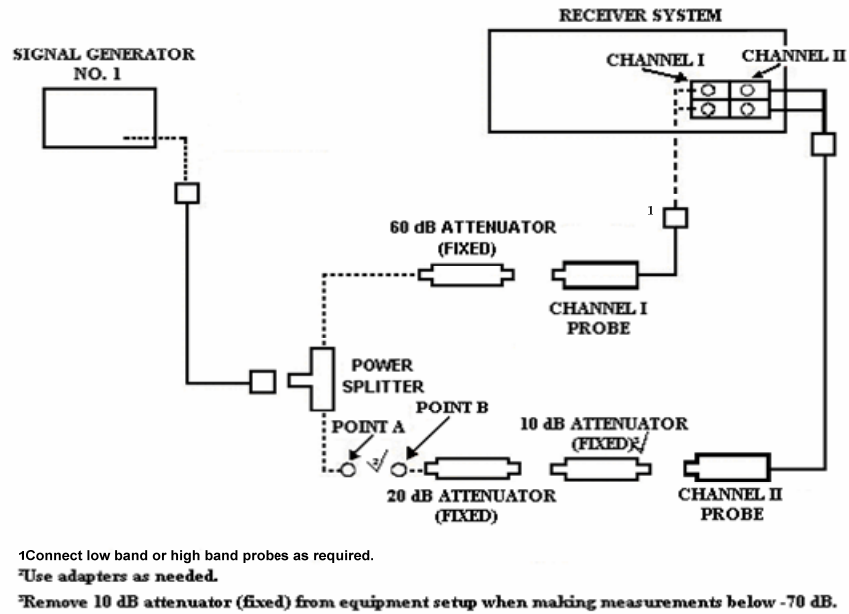

Figure 1. Equipment setup (10 MHz to 18 GHz).

## 9. Coupling and Directivity Tests

### a. Performance Check

#### NOTE

Perform (1) through (8) below for TI test frequencies from 10 MHz to 18 GHz.

Perform (9) through (19) below for TI test frequencies from 18 to 26.5 GHz.

Perform (20) through (32) below for TI test frequencies from 26.5 to 40 GHz.

(1) Adjust signal generator No. 1 frequency controls to test frequency recorded in **8 c** above and adjust **RF OUTPUT** controls for +6 dBm.

#### NOTE

Use 15 percent search on receiver system.

**NOTE**

Use adapters as needed.

**NOTE**

Use waveguide-to-coaxial adapters when TI is waveguide.

(2) Connect POINT A to POINT B (fig. 1). Press receiver system frequency to test frequency recorded in 8 c above and establish a 0.00 dB reference.

(3) Connect TI into figure 1 equipment setup as listed in (a) through (d) below:

(a) **INPUT PORT** to POINT A.

(b) **SIDEARM PORT** to POINT B.

(c) **OUTPUT PORT** to 50  $\Omega$  termination.

(d) **AUX (TEST) SIDE ARM PORT** (if any) to 50  $\Omega$  termination.

**NOTE**

Ensure receiver is in measurement mode.

(4) Record receiver system indication. Receiver system indication will be within the nominal coupling value  $\pm$ (coupling variation) + ( $\pm$ frequency sensitivity) tolerances listed for TI in Appendix A.

(5) Establish a 0.00 reference on receiver system.

(6) Connect TI into figure 1 equipment setup as listed in (a) through (d) below:

(a) **OUTPUT PORT** to POINT A.

(b) **SIDEARM PORT** to POINT B.

(c) **INPUT PORT** to 50  $\Omega$  termination.

(d) **AUX (TEST) SIDEARM PORT** (if any) to 50  $\Omega$  termination.

**NOTE**

Ensure receiver system is in measurement mode.

(7) Record receiver system indication. Receiver system indication will be greater than or equal to the value listed in TI directivity column, Appendix A.

(8) Repeat technique of (1) through (7) above for remaining test frequencies recorded in 8 c above.

**NOTE**

Perform (9) through (19) below for TI test frequencies from 18 to 26.5 GHz.



**NOTE**

Ensure equipment is connected as shown in figure 2 and has completed the 3 hour warm-up before proceeding to (9) below.

(9) Adjust signal generator No.1 frequency controls to test frequency recorded in **8 c** above and **RF OUTPUT** controls for +3 dBm.

(10) Determine signal generator No. 2 frequency (LO) required for the desired measurement by calculating the following equation:  $LO = (RF-IF)/2$  where:

RF = test frequency recorded in **8 c** above IF = intermediate frequency at which receiver system is to perform measurement (0.700 GHz).

EXAMPLE:

Let IF = 0.700 GHz

RF = 18 GHz (test frequency **8 c** above)

LO = signal generator frequency

$LO = (RF-IF)/2$

$LO = (18 \text{ GHz} - 0.700 \text{ GHz})/2$   $LO = 17.3 \text{ GHz}/2$

LO = 8.65 GHz

Signal generator No. 2 frequency for this measurement would be 8.65 GHz.

**NOTE**

Use receiver system in **15% SEARCH MODE**.

(11) Press receiver system frequency to 0.700 GHz.

(12) Adjust signal generator frequency No. 2 to value determined in (10) above and **RF OUTPUT** to +8 dBm.

(13) Connect POINT A to POINT B (fig. 2) and establish a 0.00 dBm reference on receiver system.

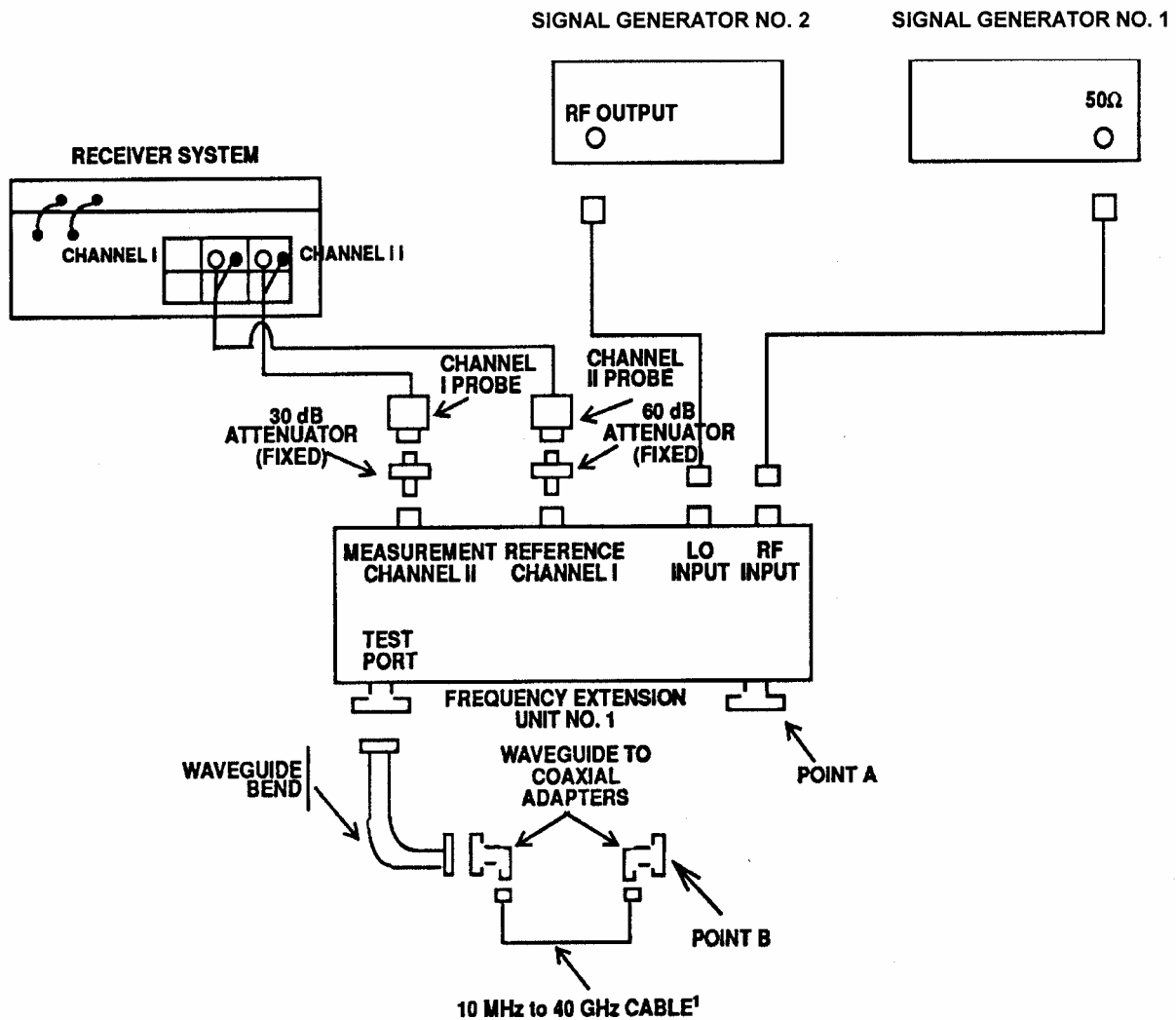

<sup>1</sup>Select appropriate cable length.

Figure 2. Equipment setup (18 to 26.5 GHz).

(14) Connect TI into figure 2 equipment setup as listed in (a) through (d) below:

- (a) **INPUT PORT** to POINT A.
- (b) **SIDEARM PORT** to POINT B.
- (c) **OUTPUT PORT** to 50 Ω termination.
- (d) **AUX (TEST) SIDEARM PORT** (if any) to 50 Ω termination.

**NOTE**

Ensure receiver system is in measurement mode.

(15) Record receiver system indication. Receiver system indication will be within the nominal coupling  $\pm$  (coupling variation) + ( $\pm$  frequency sensitivity) tolerances listed for TI in Appendix A.

(16) Establish a 0.00 dB reference on receiver system.

(17) Connect TI into figure 2 equipment setup as listed in (a) through (d) below:

- (a) **OUTPUT PORT** to POINT A.
- (b) **SIDEARM PORT** to POINT B.
- (c) **INPUT PORT** to 50  $\Omega$  termination.
- (d) **AUX (TEST) SIDEARM PORT** (if any) to 50  $\Omega$  termination.

**NOTE**

Ensure receiver system is in measurement mode.

(18) Record receiver system indication. Receiver system indication will be greater than or equal to the value listed for TI in directivity column, Appendix A.

(19) Repeat technique of (9) through (18) above for remaining test frequencies recorded in 8 c above.

**NOTE**

Perform (20) through (32) below for TI with frequency range from 26.5 to 40 GHz.

(20) Determine signal generator No. 2 (RF) frequency required for the desired measurement by calculating the following equation:  $RF = \text{test frequency in 8 c above}/3$ .

EXAMPLE A:

If test frequency recorded in 8 c above is 27 GHz,

$$RF = 27 \text{ GHz}/3$$

$$RF = 9 \text{ GHz}$$

Signal generator No. 2 frequency would be adjusted to 9 GHz.

(21) Adjust signal generator No. 2 frequency controls to value determined in (20) above and adjust **RF OUTPUT** to +3 dBm.

**TB 9-5985-314-35**

(22) Determine signal generator No. 1 frequency (LO) required for the desired measurement by calculating the following equation:  $LO = ((3 \times RF) - IF) / 2$ .

**EXAMPLE B:**

Where: RF = signal generator frequency No. 2 determined in (20) above.

IF = operating frequency of receiver system (1 GHz)

LO = Signal generator No. 1 frequency

$$LO = ((3 \times RF) - IF) / 2$$

$$LO = ((3 \times 9 \text{ GHz}) - 1 \text{ GHz}) / 2$$

$$LO = 26 \text{ GHz} / 2$$

$$LO = 13 \text{ GHz}$$

Signal generator No. 1 frequency would be adjusted to 13 GHz.

(23) Adjust signal generator No.1 controls to frequency determined in (22) above and adjust **RF LEVEL** output to 0 dBm.

(24) Connect equipment as shown in figure 3.

**NOTE**

Ensure equipment is connected as shown in figure 3 and has completed the 3 hour warm-up before proceeding to (25) below.

**NOTE**

Use **15% SEARCH MODE** on receiver system.

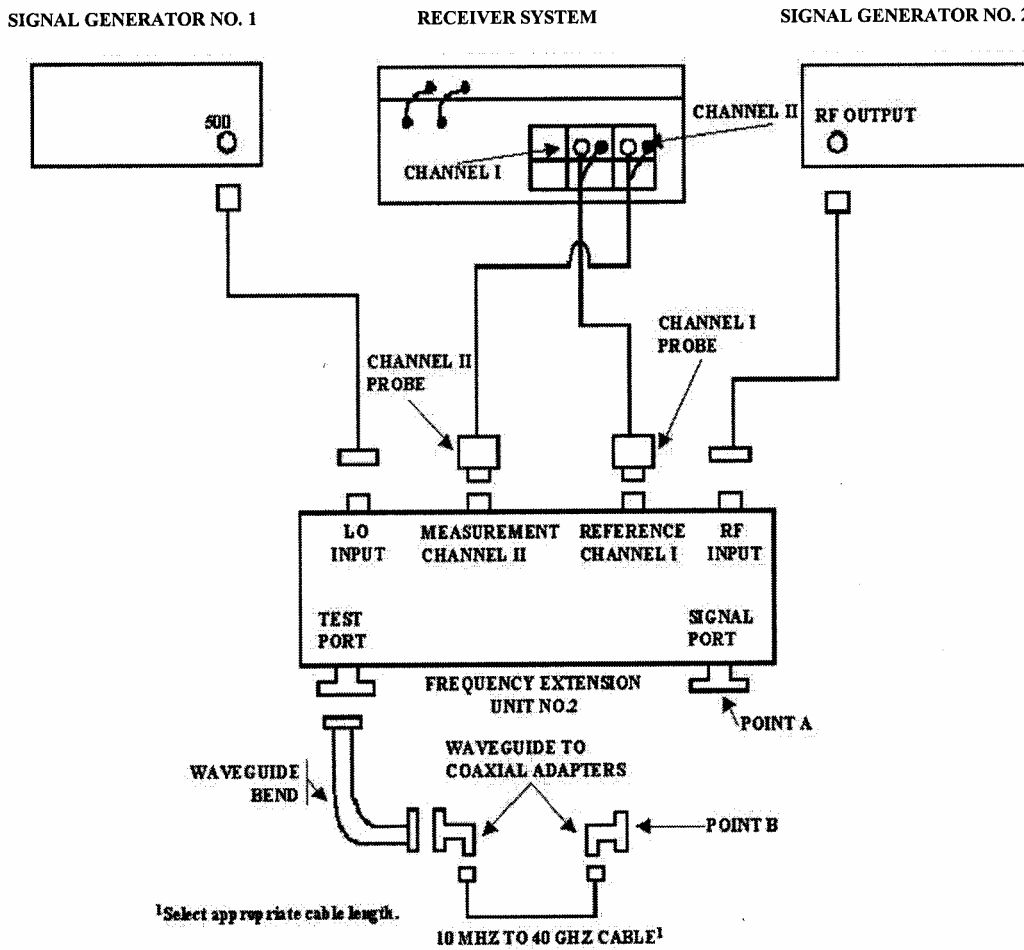

Figure 3. Equipment setup (26.5 to 40 GHz).

- (25) Press receiver frequency to 1 GHz.
- (26) Connect POINT A to POINT B (fig. 3) and establish a 0.00 dB reference on receiver system.
- (27) Connect TI into figure 3 equipment setup as listed in (a) through (d) below:
  - (a) **INPUT PORT** to POINT A.
  - (b) **SIDEARM PORT** to POINT B.

**TB 9-5985-314-35**

- (c) **OUTPUT PORT** to 50  $\Omega$  termination.
- (d) **AUX (TEST) SIDEARM PORT** (if any) to 50  $\Omega$  termination.

**NOTE**

Ensure receiver system is in measurement mode.

(28) Record receiver system indication. Receiver system indication will be within the Nominal Coupling  $\pm$  (Coupling Variation)  $\pm$  (Frequency Sensitivity) tolerances listed for TI in Appendix A.

(29) Establish a 0.00 dB reference on receiver system.

(30) Connect TI as shown in figure 3 equipment setup as listed in (a) through (d) below:

- (a) **OUTPUT PORT** to POINT A.
- (b) **SIDEARM PORT** to POINT B.
- (c) **INPUT PORT** to 50  $\Omega$  termination.
- (d) **AUX (TEST) SIDEARM PORT** (if any) to 50  $\Omega$  termination.

**NOTE**

Ensure receiver system is in measurement mode.

(31) Record receiver system indication. Receiver system indication will be greater than or equal to the value listed for TI in directivity column, Appendix A.

(32) Repeat technique of (20) through (31) above for remaining test frequencies recorded in 8 c above.

**b. Adjustment.** No adjustments can be made; however, a correction chart may be prepared listing actual coupling and directivity values at test frequencies.

**NOTE**

When determining directivity, in- or out-of-tolerance condition, all of the below must be considered:

1. Termination mismatch errors can cause measured directivity to appear slightly lower than normal.
2. A 10 percent variation in directivity is acceptable for most directional couplers used in direct support of field activities in the U. S. Army.
3. A directional coupler may be out of tolerance at a specific frequency and still be useable over the rest of its range.

**10. Final Procedure**

- a. Deenergize and disconnect all equipment.
- b. Annotate and affix DA label/form in accordance with TB 750-25.

**SECTION IV  
CALIBRATION PROCESS FOR VSWR BRIDGES**

**11. Preliminary Instructions**

- a. The instructions outlined in paragraphs **11** and **12** are preparatory to the calibration process. Personnel should become familiar with the entire bulletin before beginning the calibration.
- b. Items of equipment used in this procedure are referenced within the text by common name as listed in table 1.
- c. Unless otherwise specified, verify the result of each test and, whenever the test requirement is not met, take corrective action before continuing with the calibration.

**12. Equipment Setup**

- a. Use Appendix B to determine TI parameters for directivity.

**NOTE**

Clean all connectors with alcohol before proceeding with **b** below.

- b. Connect equipment as shown in figure 1 and allow 1 hour for equipment warm-up.

**NOTE**

Do not connect TI into equipment setup at this time.

- c. Determine and record a minimum of 10 evenly spaced test frequencies over the TI entire frequency range.

**13. Directivity**

**a. Performance Check**

- (1) Adjust signal generator No. 1 controls to test frequency recorded in **12 c** above and adjust **RF OUTPUT** controls for +6 dBm. Connect N-short to TI **DEVICE UNDER TEST** port.





(7) Adjust signal generator No. 1 controls to test frequency recorded in **12 c** above and adjust **RF OUTPUT** controls for +6 dBm. Leave **TI DEVICE UNDER TEST** port open.

(8) Connect TI as shown in figure 1 equipment setup. Press receiver system frequency to test frequency recorded in **12 c** above.

**NOTE**

Use **15% SEARCH MODE** on receiver system.

(9) Establish a 0.0 dB reference on receiver system.

**NOTE**

Ensure receiver is in measurement mode.

(10) Connect mismatches as listed in table 2 to **TI DEVICE UNDER TEST** port.

(11) Record receiver system indication in table 4.

Table 4. Return Loss Measurements (without N-Short)

Test frequency	Mismatch 2334-001-1	Mismatch 2334-001-2	Mismatch 2334-001-3	Mismatch 2334-001-4

(12) Repeat technique of (7) through (11) above for remaining test frequencies recorded in **12 c** above.

(13) Add readings from table 3 and table 4 then divide by 2. Return loss in dB indication will be within the limits specified in table 2 (for secondary reference as stated in test report plus or minus specifications of SWR bridges).

**b. Adjustments.** No adjustments can be made.

**14. Final Procedure**

- a. Deenergize and disconnect all equipment and reinstall protective cover on TI.
- b. Annotate and affix DA label/form in accordance with TB 750-25.

**SECTION V  
CALIBRATION PROCESS FOR  
COAXIAL CIRCULATORS**

**15. Preliminary Instructions**

a. The instructions outlined in paragraphs **15** through **17** are preparatory to the calibration process. Personnel should become familiar with the entire bulletin before beginning the calibration.

b. Items of equipment used in this procedure are referenced within the text by common name.

c. Unless otherwise specified, verify the results of each test and, whenever the test requirement is not met, take corrective action before continuing with the calibration.

**16. Definitions.** Explanation of terms peculiar to coaxial circulators is listed in **a** through **d** below to ensure accurate interpretation of the measurement techniques used in this procedure.

**a. Isolation.** Electrical or acoustical separation between two locations is normally expressed in dB (a measurement against energy flow).

**b. Insertion loss.** The difference between the power received at the load before and after the insertion of apparatus at some point in the line and normally expressed in dB (a measurement made with forward energy flow).

**c. Forward energy flow.** The direction in which energy is allowed to pass through a device with very little RF loss.

**d. Reverse energy flow.** The direction in which RF energy is opposed in passing through the device.

**17. Equipment Setup**

**NOTE**

Use Appendix C to determine TI parameters for isolation and insertion loss.

**NOTE**

Clean all connectors with alcohol.

Connect equipment as shown in figure 1, and allow 1 hour for equipment warm-up.

**NOTE**

Do not connect TI into equipment setup at this time.

**18. Insertion Loss and Isolation**

**a. Performance Check**

(1) Adjust signal generator No. 1 frequency controls to 0.960 GHz and adjust **RF OUTPUT** controls for +6 dBm.

**NOTE**

Use **15% SEARCH MODE** on receiver system.

(2) Connect POINT A to POINT B (fig. 1) and establish a reference 0.00 dB on receiver system at 0.960 GHz.

(3) Connect TI into figure 1 equipment setup as listed in (a) through (c) below:

- (a) **INPUT PORT** to POINT A.
- (b) **OUTPUT PORT** to POINT B.
- (c) **SIDE PORT** to 50 Ω termination.

(4) Receiver system indication will be 0.5 dB or less.

(5) Adjust signal generator No. 1 and receiver system frequency controls to frequency settings listed in table 5. Receiver system indication will be 0.5 dB or less.

Table 5. Coaxial Circulator Frequencies

GHz
0.960
1.000
1.030
1.060
1.090
1.100

(6) Repeat (1) and (2) above.

(7) Connect TI into figure 1 equipment setup as listed in (a) through (c) below:

- (a) **OUTPUT PORT** to POINT A.

**TB 9-5985-314-35**

- (b) **INPUT PORT** to POINT B.
  - (c) **SIDE PORT** to 50  $\Omega$  termination.
- (8) Receiver system indication will be 20 dB or greater.
- (9) Adjust signal generator No. 1 and receiver system frequency controls to frequency settings listed in table 5. Receiver system indication will be 20 dB or greater.
- (10) Repeat (1) and (2) above.
- (11) Connect TI into figure 1 equipment setup as listed in (a) through (c) below:
- (a) **OUTPUT PORT** to POINT A.
  - (b) **SIDE PORT** to POINT B.
  - (c) **INPUT PORT** to 50  $\Omega$  termination.
- (12) Receiver system indication will be 0.5 dB or less.
- (13) Adjust signal generator No. 1 and receiver system frequency controls to frequency settings listed in table 5. Receiver system indication will be 0.5 dB or less.
- (14) Repeat (1) and (2) above.
- (15) Connect TI into figure 1 equipment setup as listed in (a) through (c) below:
- (a) **SIDE PORT** to POINT A.
  - (b) **OUTPUT PORT** to POINT B.
  - (c) **INPUT PORT** to 50  $\Omega$  termination.
- (16) Receiver system will indicate 20 dB or greater.
- (17) Adjust signal generator No. 1 and receiver system frequency controls to frequency settings listed in table 5. Receiver system indication will be 20 dB or greater.
- (18) Repeat (1) and (2) above.
- (19) Connect TI into figure 1 equipment setup as listed in (a) through (c) below:
- (a) **SIDE PORT** to POINT A.
  - (b) **INPUT PORT** to POINT B.
  - (c) **OUTPUT PORT** to 50  $\Omega$  termination.
- (20) Receiver system indication will be 0.5 dB or less.

(21) Adjust signal generator No. 1 and receiver system frequency controls to frequency settings listed in table 5. Receiver system indication will be 0.5 dB or less.

(22) Repeat (1) and (2) above.

(23) Connect TI as shown in figure 1, equipment setup as listed in (a) through (c) below:

(a) **INPUT PORT** to POINT A.

(b) **SIDE PORT** to POINT B.

(c) **OUTPUT PORT** to 50  $\Omega$  termination.

(24) Receiver system indication will be 20 dB or greater.

(25) Adjust signal generator No. 1 and receiver system frequency controls to frequency settings listed in table 5. Receiver system indication will be 20 dB or greater.

**b. Adjustments.** No adjustments can be made.

## **19. Final Procedure**

**a.** Deenergize and disconnect all equipment and reinstall protective cover on TI.

**b.** Annotate and affix DA label/form in accordance with TB 750-25.

# **SECTION VI CALIBRATION PROCESS FOR POWER SPLITTERS AND POWER DIVIDERS**

## **20. Preliminary Instructions**

**a.** The instructions outlined in paragraphs **20** and **21** are preparatory to the calibration process. Personnel should become familiar with the entire bulletin before beginning the calibration.

**b.** Items of equipment used in this procedure are referenced within the text by common name.

**c.** Unless otherwise specified, verify the results of each test and, whenever the test requirement is not met, take corrective action before continuing with the calibration.

## **21. Equipment Setup**

**a.** Use Appendix D to determine TI parameters for insertion loss and output tracking.

**NOTE**

Clean all connectors with alcohol before proceeding with **b** below.

**b.** Connect equipment as shown in figure 4 for TIs with frequency range from 10 MHz to 18 GHz. Allow 1 hour for equipment warm-up.

**NOTE**

Equipment shown in figure 5 is for TIs with frequency range from 18 to 26.5 GHz. Allow 3 hours for equipment warm-up.

**NOTE**

Equipment shown in figure 6 is for TIs with frequency range from 26.5 to 40 GHz. Allow 3 hours for equipment warm-up.

**NOTE**

Do not connect TI into equipment setup at this time.

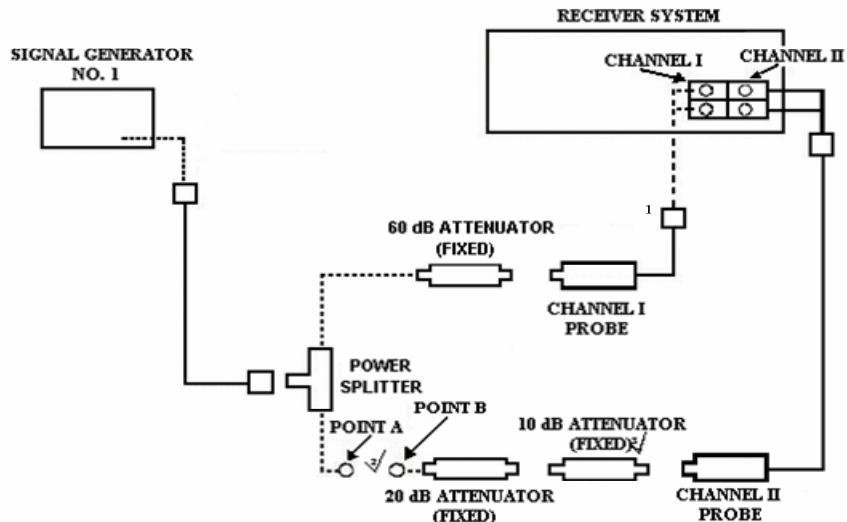

<sup>1</sup>Connect low band or high band probes as required.

<sup>2</sup>Use adapters as needed.

<sup>3</sup>Remove 10 dB attenuator (fixed) from equipment setup when making measurements below -70 dB.

Figure 4. Power splitter measurement (10 MHz to 18 GHz) - equipment setup.

## 22. Insertion Loss and Output Port Tracking

### a. Performance Check

#### NOTE

Perform 1 through 4 below for TIs with frequency range listed in Appendix D specifications.

1. 10 MHz to 1.9 GHz perform (1) through (11).
2. 2 to 18 GHz perform (12) through (22).
3. 18 to 26.5 GHz perform (23) through (35).
4. 26.5 to 40 GHz perform (36) through (48).

(1) Connect equipment as shown in figure 4.

(2) Adjust signal generator No. 1 frequency controls to 10 MHz and adjust **RF OUTPUT** controls for +6 dBm.

#### NOTE

Use **15% SEARCH MODE** on receiver system.

(3) Connect POINT A to POINT B (fig. 4) and establish a 0.00 dB reference on receiver system at 10 MHz.

(4) Connect TI into 4 equipment setup as listed in (a) through (c) below:

- (a) **INPUT PORT 1** to POINT A.
- (b) **OUTPUT PORT 2** to POINT B.
- (c) **OUTPUT PORT 3** to 50  $\Omega$  termination.

(5) Record receiver system indication in table 6 insertion loss for **OUTPUT PORT 2** column.

(6) Adjust receiver system and signal generator No. 1 frequency controls to remaining test frequency settings listed in table 6. Record receiver system indication in insertion loss for **OUTPUT PORT 2** column in table 6. Insertion loss will be equal to or less than the limits listed in Appendix D.

Table 6. Insertion Loss - Output Port Tracking (10 MHz to 1.9 GHz)

Test frequency (GHz)	Receiver system indication insertion loss		<b>OUTPUT PORT TRACKING</b> (dB)
	<b>OUTPUT PORT 2</b> (dB)	<b>OUTPUT PORT 3</b> (dB)	
0.010			
0.050			
0.100			
0.280			
0.460			
0.640			
0.820			
1.000			
1.180			
1.360			
1.540			
1.720			
1.900			

- (7) Disconnect TI from equipment setup and repeat (2) and (3) above.
- (8) Connect TI into figure 4 equipment setup as listed in (a) through (c) below:
  - (a) **INPUT PORT 1** to POINT A.
  - (b) **OUTPUT PORT 3** to POINT B.
  - (c) **OUTPUT PORT 2** to 50 Ω termination.

(9) Record receiver system indication in table 4 insertion loss for **OUTPUT PORT 3** column.

(10) Press receiver system and signal generator No. 1 frequency controls to remaining frequency settings listed in table 6. Record receiver system indication in insertion loss for **OUTPUT PORT 3** column in table 6. Insertion loss will be equal to dBm or less than the limits listed in Appendix D.

(11) Algebraically calculate the difference between the values recorded for **OUTPUT PORT 2** and **OUTPUT PORT 3** in table 6. Record results in **OUTPUT PORT TRACKING** column in table 6. Output tracking will be within the limits specified in Appendix D.

**NOTE**

Perform (12) through (22) below for TI with frequency range from 2 to 18 GHz.

- (12) Connect equipment as shown in figure 4.



(13) Adjust signal generator No. 1 frequency to 2.000 GHz and adjust **RF OUTPUT** controls for +6 dBm.

**NOTE**

Use **15% SEARCH MODE** on receiver system.

(14) Connect POINT A to POINT B (fig. 4) and establish a 0.00 dB reference on receiver system at 2.000 GHz.

(15) Connect TI into figure 4 equipment setup as listed in (a) through (c) below:

- (a) **INPUT PORT 1** to POINT A.
- (b) **OUTPUT PORT 2** to POINT B.
- (c) **OUTPUT PORT 3** to 50 Ω termination.

(16) Record receiver system indication in **OUTPUT PORT 2** column of table 7.

(17) Adjust signal generator No. 1 and receiver system frequency controls to measure and record insertion loss for **OUTPUT PORT 2** for remaining frequencies listed in table 7. Insertion loss will be equal to or less than the limits listed in Appendix D.

Table 7. Insertion Loss - Output Port Tracking (2 to 18 GHz)

Test frequency (GHz)	Receiver system indication insertion loss		<b>OUTPUT PORT TRACKING</b> (dB)
	<b>OUTPUT PORT 2</b> (dB)	OUTPUT PORT 3 (dB)	
2.000			
2.500			
3.000			
3.500			
4.000			
4.500			
5.000			
5.500			
6.000			
6.500			
7.000			
7.500			
8.000			
8.500			
9.000			
9.500			
10.000			
10.500			
11.000			
11.500			
12.000			
12.500			
13.000			
13.500			
14.000			

Table 7. Insertion Loss - Output Port Tracking (2 to 18 GHz) Continued

Test frequency (GHz)	Receiver system indication insertion loss		<b>OUTPUT PORT TRACKING</b> (dB)
	<b>OUTPUT PORT 2</b> (dB)	<b>OUTPUT PORT 3</b> (dB)	
14.500			
15.000			
15.500			
16.000			
16.500			
17.000			
17.500			
18.000			

- (18) Disconnect TI from equipment setup and repeat (13) and (14) above.
- (19) Connect TI into figure 4 equipment setup as listed in (a) through (c) below:
  - (a) **INPUT PORT 1** to POINT A.
  - (b) **OUTPUT PORT 3** to POINT B.
  - (c) **OUTPUT PORT 2** to 50 Ω termination.
- (20) Record receiver system indication in **OUTPUT PORT 3** column of table 7.

(21) Adjust signal generator No. 1 and receiver system frequency controls to measure and record insertion loss for **OUTPUT PORT 3** for remaining frequencies listed in table 7. Insertion loss will be equal to or less than the limits listed in Appendix D.

(22) Algebraically calculate the difference between the values recorded for **OUTPUT PORT 2** and **OUTPUT PORT 3** columns of table 7. Record difference in **OUTPUT PORT TRACKING** column in table 7. Output tracking will be within the limits specified in Appendix D.

**NOTE**

Perform (23) through (35) below for TI with frequency range from 18 to 26.5 GHz.

- (23) Connect equipment as shown in figure 5.
- (24) Adjust signal generator No. 1 frequency controls to 18000 MHz and adjust **RF OUTPUT** controls for +3 dBm.
- (25) Press signal generator No .2 frequency to 8650 MHz and adjust **RF OUTPUT** controls for +8 dBm.

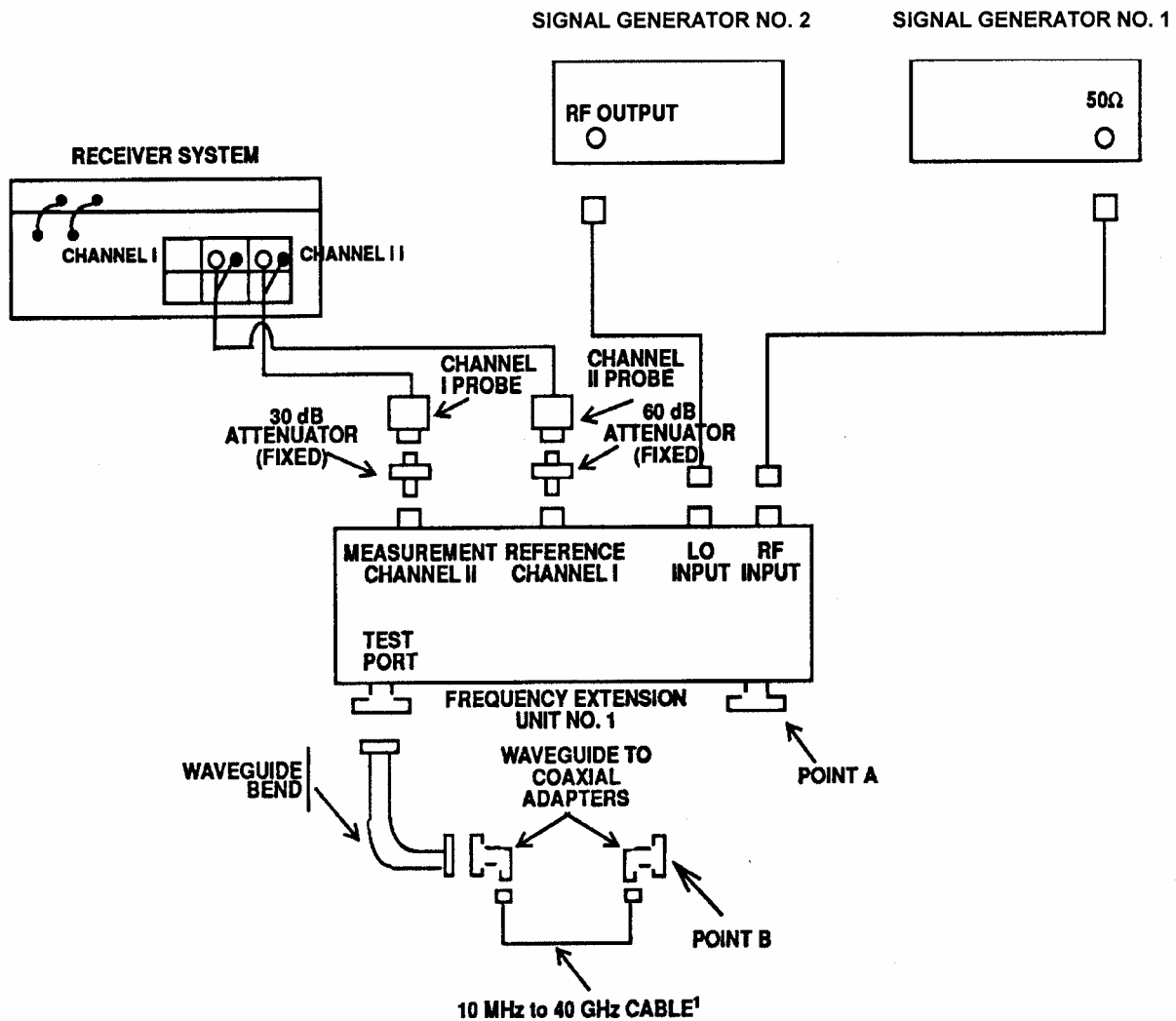

<sup>1</sup>Select appropriate cable length.

Figure 5. Power splitter measurement (18 to 26.5 GHz) - equipment setup.

**NOTE**

Use 15% **SEARCH MODE** on receiver system.

(26) Press receiver system frequency to 0.700 GHz.

(27) Connect POINT A to POINT B (fig. 5) and establish a 0.00 dB reference on receiver system.

**TB 9-5985-314-35**

(28) Connect TI into figure 5 equipment setup as listed in (a) through (c) below:

- (a) **INPUT PORT 1** to POINT A.
- (b) **OUTPUT PORT 2** to POINT B.
- (c) **OUTPUT PORT 3** to 50 Ω termination.

(29) Record receiver system indication in **OUTPUT PORT 2** column of table 8.

(30) Adjust signal generator No. 1 and signal generator No. 2 frequency controls to remaining frequency settings listed in table 8. Measure and record insertion loss for **OUTPUT PORT 2** column in table 8. Insertion loss will be approximately equal to value listed in Appendix D.

Table 8. Insertion Loss - Output Port Tracking (18 to 26.5 GHz)

Programmable sweep generator (GHz)	Signal generator (MHz)	Receiver system indication insertion loss		<b>OUTPUT PORT TRACKING</b> (dB)
		<b>OUTPUT PORT 2</b> (dB)	<b>OUTPUT PORT 3</b> (dB)	
18.000	8650			
18.500	8900			
19.000	9150			
19.500	9400			
20.000	9650			
20.500	9900			
21.000	10,150			
21.500	10,400			
22.000	10,650			
22.500	10,900			
23.000	11,150			
23.500	11,400			
24.000	11,650			
24.500	11,900			
25.000	12,150			
25.500	12,400			
26.000	12,650			
26.500	12,900			

(31) Repeat (24), (25), and (27) above.

(32) Connect TI into figure 5 equipment setup as listed in (a) through (c) below:

- (a) **INPUT PORT 1** to POINT A.
- (b) **OUTPUT PORT 3** to POINT B.
- (c) **OUTPUT PORT 2** to 50 Ω termination.

(33) Record receiver system indication in **OUTPUT PORT 3** column of table 8.

(34) Adjust signal generator No. 1 and signal generator No. 2 frequency controls to remaining settings listed in table 8. Measure and record insertion loss for **OUTPUT PORT 3** in table 8. Insertion loss will be approximately equal to value listed in Appendix D.

(35) Algebraically calculate the difference between the values recorded in table 8 for **OUTPUT PORT 2** and **OUTPUT PORT 3**. Record difference in **OUTPUT PORT TRACKING** column of table 8. Output tracking will be within the limits specified listed in Appendix D.

**NOTE**

Perform (36) through (48) below for TI with frequency range from 26.5 to 40 GHz.

(36) Connect equipment as shown in figure 6.

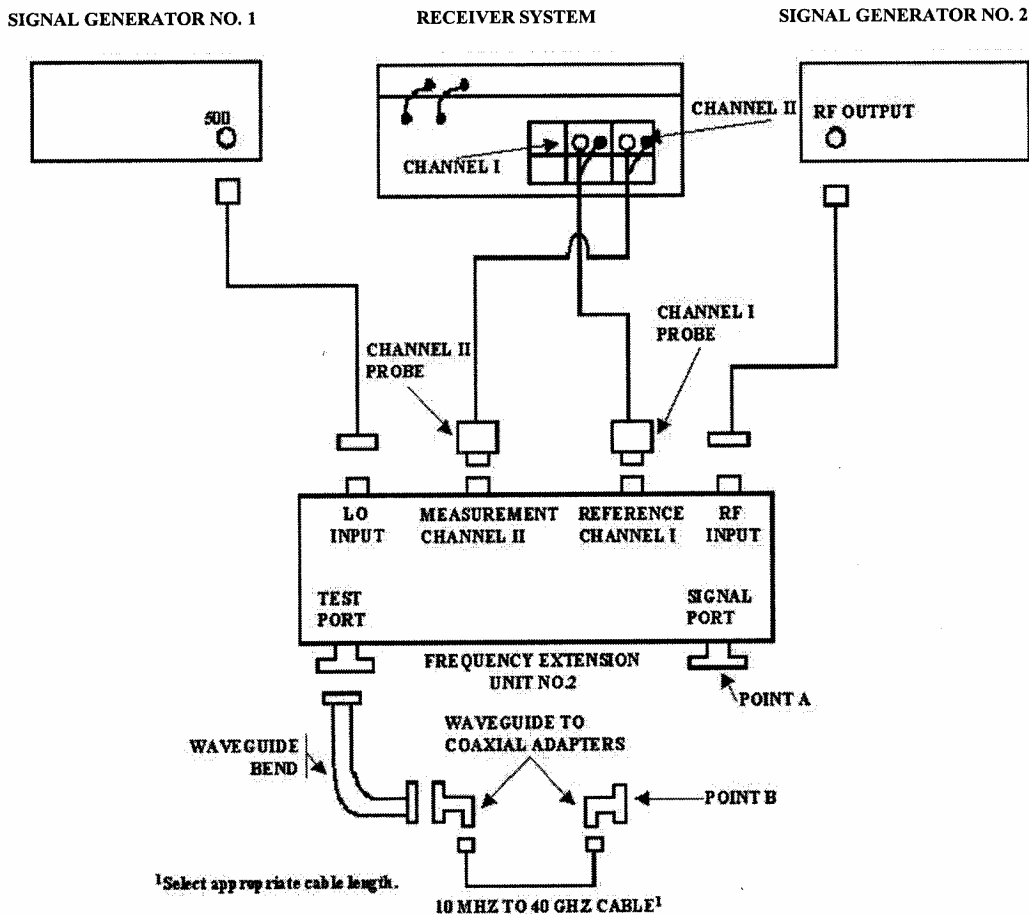

Figure 6. Power splitter measurement (26.5 to 40 GHz) - equipment setup

**TB 9-5985-314-35**

(37) Adjust signal generator No. 1 frequency controls to 13.0 GHz **RF OUTPUT** controls for 0 dBm.

(38) Adjust signal generator No. 2 frequency controls to 9000 MHz and **RF OUTPUT** controls for +3 dBm.

**NOTE**

Use **15% SEARCH MODE** on receiver system.

(39) Press receiver system frequency to 1.000 GHz.

(40) Connect POINT A to POINT B (fig. 6) and establish a 0.00 dB reference on receiver system.

(41) Connect TI into figure 6 equipment setup as listed in (a) through (c) below:

- (a) **INPUT PORT 1** to POINT A.
- (b) **OUTPUT PORT 2** to POINT B.
- (c) **OUTPUT PORT 3** to 50 Ω termination.

(42) Record receiver system indication in **OUTPUT PORT 2** column of table 9.

(43) Set signal generator No. 1 and signal generator No. 2 frequency controls to remaining settings listed in table 9. Measure and record insertion loss for **OUTPUT PORT 2** column in table 9.

Table 9. Insertion Loss - Output Port Tracking (26.5 to 40 GHz)

Actual test frequency (GHz)	Programmable sweep generator (LO) (GHz)	Signal generator (RF) (MHz)	Receiver system indication insertion loss		<b>OUTPUT PORT TRACKING</b> (dB)
			<b>OUTPUT PORT 2</b> (dB)	<b>OUTPUT PORT 3</b> (dB)	
27.0	13.0	9000			
28.0	13.5	9333			
29.0	14.0	9667			
30.0	14.5	10,000			
31.0	15.0	10,333			
32.0	15.5	10,667			
33.0	16.0	11,000			
34.0	16.5	11,333			
35.0	17.0	11,667			
36.0	17.5	12,000			
37.0	18.0	12,333			
38.0	18.5	12,667			
39.0	19.0	13,000			
40.0	19.5	13,333			

(44) Repeat (37) through (40) above.

(45) Connect TI into figure 6 equipment setup as listed in (a) through (c) below:

- (a) **INPUT PORT 1** to POINT A.
- (b) **OUTPUT PORT 3** to POINT B.
- (c) **OUTPUT PORT 2** to 50  $\Omega$  termination.

(46) Record receiver system indication in **OUTPUT PORT 3** column of table 9.

(47) Adjust signal generator No. 1 and signal generator No. 2 frequency controls to remaining settings listed in table 9. Measure and record insertion loss for **OUTPUT PORT 3** in table 9.

(48) Algebraically calculate the difference between the values recorded in table 9 for **OUTPUT PORT 2** and **OUTPUT PORT 3**. Record difference in **OUTPUT PORT TRACKING** column of table 9. Output port tracking will be within the limits specified in Appendix D.

**b. Adjustments.** Prepare charts (if required) similar to tables 7, 8, and 9 for TI frequency range.

### **23. Final Procedure**

- a. Deenergize and disconnect all equipment and reinstall protective cover on TI.
- b. Annotate and affix DA label/form in accordance with TB 750-25.





**APPENDIX A**  
**DIRECTIONAL COUPLERS**  
**TEST INSTRUMENT IDENTIFICATION**

Model/part number	Manufacturer	Frequency range (GHz)	Nominal coupling (dB) <sup>1 2</sup>	Coupling variation (dB) <sup>1 2</sup>	Frequency sensitivity (dB) <sup>1 2</sup>	Directivity (dB) <sup>1</sup>
A414-10-FS1	PRD Electronic	26.5 to 40.0	10	±0.4 <sup>3</sup>	±0.5	40
CA-1 5N	MICROLAB/FXR	0.20 to 0.40	3(+0.2-0.0)	---	±0.5	25
C901 E	Wavecom	3.7 to 8.3	10	±0.3	N/A	37
DBH-675-10	Systron	7.05 to 10.0	10(±0.4)	±0.5	N/A	40
H752A	Hewlett-Packard	7.05 to 10.0	3	±0.5	N/A	40
H752C	Hewlett-Packard	7.05 to 10.0	10	±0.5	N/A	40
H752D	Hewlett-Packard	7.05 to 10.0	20	±0.5	N/A	40
K414-10-FS1	PRD Electronic	18.0 to 26.5	10	±0.4	±0.5	40
K752C	Hewlett-Packard	18.0 to 26.5	10	±0.5	N/A	40
L901 E	Wavecom	0.9 to 2.2	10	±0.5	N/A	45
MIS-10409-21	Military	Same as L901 E	---	---	---	---
MIS-10409-31	Military	Same as S901 E	---	---	---	---
M1537014-012	Military	Same as K414-10-FS1	---	---	---	---
P7520	Hewlett-Packard	12.4 to 18.0	10	±0.5	N/A	40
P752D	Hewlett-Packard	12.4 to 18.0	20	±0.5	N/A	40
P901	Wavecom	0.5 to 1.0	10	N/A	N/A	48
R752C	Hewlett-Packard	26.5 to 40.0	10	±0.6	N/A	40
S901 E	Wavecom	1.7 to 4.2	10	N/A	N/A	42
U901	Wavecom	0.1 to 0.5	10	±0.5	N/A	48
X752A	Hewlett-Packard	8.2 to 12.4	3(±0.4)	±0.5	N/A	40
X752C	Hewlett-Packard	8.2 to 12.4	10(±0.4)	±0.5	N/A	40
X752D	Hewlett-Packard	8.2 to 12.4	20 (±0.4)	±0.5	N/A	40
X901	Wavecom	7.0 to 12.4	10	±0.3	N/A	33
1070-10	Narda	8.2 to 12.4	10 ±0.2	±0.4	±0.5	40
11691 D OPT001	Hewlett-Packard	2.0 to 18.0	22	±1.0	N/A	30 (2.0 to 8 GHz) 26(8 to 18 GHz) 24 (w/N- type connector)
11692D	Hewlett-Packard	2.0 to 18.0	22	±1.0	N/A	Same as 11691D and 24 test port (w/N-type connector)
3000-10	Narda	0.225 to 0.46	10±(0.1) <sup>4</sup>	±1.0	N/A	30
3000-20	Narda	0.225 to 0.46	20 (±0.1) <sup>4 5</sup>	±1.0	N/A	30
3000-30	Narda	0.225 to 0.46	30 (±0.1) <sup>4 5</sup>	±1.0	N/A	30
3001-10	Narda	0.46 to 0.95	10 (±0.1) <sup>4</sup>	±1.0	N/A	30
3001-20	Narda	0.46 to 0.95	20 (±0.1) <sup>4 5</sup>	±1.0	N/A	30
3002-10	Narda	0.95 to 2.0	10 (±0.1) <sup>4</sup>	±1.0	N/A	30
3002-20	Narda	0.95 to 2.0	20 (±0.1) <sup>4 5</sup>	±1.0	N/A	30
3002-30	Narda	0.95 to 2.0	30 (±0.1) <sup>4 5</sup>	±1.0	N/A	30

See footnotes at end of table.

**APPENDIX A**  
**DIRECTIONAL COUPLERS**  
**TEST INSTRUMENT IDENTIFICATION - CONTINUED**

Model/part number	Manufacturer	Frequency range (GHz)	Nominal coupling (dB) <sup>1 2</sup>	Coupling variation (dB) <sup>1 2</sup>	Frequency sensitivity (dB) <sup>1 2</sup>	Directivity (dB) <sup>1</sup>
3003-10	Narda	2.0 to 4.0	10 ( $\pm 0.1$ ) <sup>4</sup>	$\pm 1.0$	N/A	25
3003-20	Narda	2.0 to 4.0	20 ( $\pm 0.1$ ) <sup>4 5</sup>	$\pm 1.0$	N/A	27
3004-10	Narda	4.0 to 10.0	10 ( $\pm 0.4$ ) <sup>4</sup>	N/A	$\pm 1.2$	20 (4 to 8 GHz) 17 (8 to 10 GHz)
3004-20	Narda	4.0 to 10.0	20 ( $\pm 0.4$ ) <sup>4 5</sup>	N/A	$\pm 1.2$	20 (4 to 8 GHz) 17 (8 to 10 GHz)
3020A	Narda	0.05 to 1.0  0.25 to 1.0	20 to 33 (0.05 to 0.25 GHz) ( $\pm 0.1$ ) <sup>5</sup> 20 (0.25 to 1.0 GHz)	N/A  $\pm 1.0$ (0.25 to 1.0 GHz)	N/A	35
3022	Narda	1 to 4	20 ( $\pm 0.1$ ) <sup>4 5</sup>	$\pm 1.0$	N/A	1 to 3 GHz 30 3 to 4 GHz 27
3024	Narda	4.0 to 8.0	20 ( $\pm 0.1$ ) <sup>4 5</sup>	$\pm 1.0$	N/A	25
3039-20	Narda	0.125 to 0.25	20 ( $\pm 0.1$ ) <sup>4 5</sup>	$\pm 0.5$	$\pm 0.2$	20
3043B-10	Narda	1.7 to 4.2	10 ( $\pm 0.1$ ) <sup>4</sup>	$\pm 0.5$	$\pm 0.2$	20
3043B-20	Narda	1.7 to 4.2	20 ( $\pm 0.1$ ) <sup>4 5</sup>	$\pm 0.5$	$\pm 0.2$	20
3044B-20	Narda	3.7 to 8.3	20 ( $\pm 0.1$ ) <sup>4 5</sup>	$\pm 0.5$	$\pm 0.2$	17
3045C-10	Narda	7.0 to 12.4	10 ( $\pm 0.1$ ) <sup>4</sup>	$\pm 0.5$	$\pm 0.2$	15
3045C-20	Narda	7.0 to 12.4	20 ( $\pm 0.1$ ) <sup>4 5</sup>	$\pm 0.5$	$\pm 0.2$	15
3045C-30	Narda	7.0 to 12.4	30 ( $\pm 0.1$ ) <sup>4 5</sup>	$\pm 0.5$	$\pm 0.2$	15
3060-20	Narda	10 to 200 MHz <sup>6</sup>	20 ( $\pm 0.2$ ) <sup>4 5</sup>	$\pm 0.8$	$\pm 0.5$	20
3092	Narda	0.95 to 2.2	10 ( $\pm 0.1$ ) <sup>4</sup>	N/A	$\pm 1.2$	45
3093	Narda	1.7 to 4.2	10 ( $\pm 0.1$ ) <sup>4</sup>	N/A	$\pm 1.2$	42
3094	Narda	3.7 to 8.3	10 ( $\pm 0.1$ ) <sup>4</sup>	N/A	$\pm 1.2$	37
30953	Narda	7.0 to 12.4	10 ( $\pm 0.1$ ) <sup>4</sup>	N/A	$\pm 1.2$	33
4002B-10	Narda	0.125 to 0.25	10 ( $\pm 1.25$ )	N/A	$\pm 0.75$	25
40852	PRD Electronic	8.2 to 12.4	10	3	$\pm 0.6$	40
40854	PRD Electronic	8.2 to 12.4	20	$\pm 0.4$	$\pm 0.5$	40
413S1	PRD Electronic	12.4 to 18.0	10	$\pm 0.4$	$\pm 0.5$	40
430-10S1	PRD Electronic	0.2 to 1.0	10	$\pm 1.0$	$\pm 0.2$	20
431-10S1	PRD Electronic	0.95 to 2.0	10	$\pm 1.0$	$\pm 0.2$	15
432-10S1	PRD Electronic	2.0 to 4.0	10	$\pm 1.0$	$\pm 0.2$	15
432-20S2	PRD Electronic	2.0 to 4.0	20	$\pm 0.5$	$\pm 1.0$	25
433-10S1	PRD Electronic	4.0 to 8.0	10	$\pm 1.0$	$\pm 0.2$	15
433-10S2	PRD Electronic	4.0 to 8.0	10	$\pm 0.5$	$\pm 1.0$	20
434-10S1	PRD Electronic	7.0 to 11.0	10	$\pm 1.0$	$\pm 0.2$	15
60543	Waveline	8.2 to 12.4	10	$\pm 0.4$	$\pm 0.5$	40
674-40	Waveline	8.2 to 12.4	40( $\pm 0.3$ )	$\pm 0.5$	N/A	40

See footnotes at end of table.

**APPENDIX A  
DIRECTIONAL COUPLERS  
TEST INSTRUMENT IDENTIFICATION - CONTINUED**

Model/part number	Manufacturer	Frequency range (GHz)	Nominal coupling (dB) <sup>1 2</sup>	Coupling variation (dB) <sup>1 2</sup>	Frequency sensitivity (dB) <sup>1 2</sup>	Directivity (dB) <sup>1</sup>
774-30	Waveline	12.4 to 18.0	30(±0.3)	±0.5	N/A	40
774-40	Waveline	12.4 to 18.0	40(±0.3)	±0.5	N/A	40
776D	Hewlett-Packard	0.94 to 1.9	20	±1.0	N/A	40
778D	Hewlett-Packard	0.1 to 2.0	20 <sup>7</sup>	±1.5 <sup>8</sup>	±1.0	36 (0.1 to 1.0 GHz) 32 (1 to 2 GHz) 30 (0.1 to 2 GHz, B port)
7913359-2-2	Military	8.2 to 12.4	10	±0.4	±0.5	40
797D	Hewlett-Packard	1.9 to 4.1	20(±0.5)	±0.2	N/A	26
7923152	Military	Same as K414-40-FS1	---	---	---	---
7923153	Military	Same as A414-10-FSI	---	---	---	---
874-40	Waveline	18.0 to 26.5	40 (±0.3)	±0.5	N/A	40

<sup>1</sup>See paragraph 7 for definitions.

<sup>2</sup>Nominal coupling tolerances are the linear combination of coupling variation and frequency sensitivity nominal coupling tolerance (± (coupling variation) + (± (frequency sensitivity). Example: Hewlett-Packard, Model 776D - 20 (nominal coupling) = 20 ±1 dB over TI's frequency range.

<sup>3</sup>Provide correction chart of receiver system actual indications.

<sup>4</sup>Absolute calibration accuracy for manufacturer selected frequencies stamped on data plate of TI.

<sup>5</sup>Per 10 dB step.

<sup>6</sup>Use test frequencies of: 10, 30, 60, 100, 150, and 200 MHz.

<sup>7</sup>Decreasing frequency from 0.45 to 0.1 GHz has an increasing slope of 0.006 dB/MHz. Example: nominal coupling (dB) at 0.1 GHz is 22.1.

<sup>8</sup>Above 0.45 GHz.



**APPENDIX B  
VSWR BRIDGES  
TEST INSTRUMENT IDENTIFICATION**

Model/part number	Manufacturer	Frequency range (GHz)	Directivity (dB)
60NF50	Wiltron	5 MHz to 2 GHz <sup>1</sup>	40
87A50-1	Wiltron	2 to 18 GHz	38 <sup>2</sup>

<sup>1</sup> Not calibrated below 10 MHz.

<sup>2</sup> For model number 87A50-1/SC3522 Directivity is specified at 36 dB.



**APPENDIX C  
THREE PORT CIRCULATOR  
TEST INSTRUMENT IDENTIFICATION**

Model/part number	Manufacturer	Frequency range (GHz)	Isolation (dB min)	Insertion loss (dB max)
DF 2407	Ditcom Microwave	Same as M3B-1030		
M3B-1030	Omnispectra	0.960 to 1.100	20	0.5
7916840	Same as M3B-1030			





**APPENDIX D  
POWER SPLITTERS AND POWER DIVIDERS  
TEST INSTRUMENT IDENTIFICATION**

Model/part number	Manufacturer	Frequency range (GHz) <sup>1</sup>	Insertion loss (dB nom)	OUTPUT PORT TRACKING (dB) <sup>2</sup>
K241 () <sup>3</sup>	Wiltron	Dc to 40		
		Dc to 6	7.0	±0.3
		6 to 18	7.5	±0.3
		18 to 26.5	8.0	±0.6
		26.5 to 40	8.5	±0.6
PS018	Weinschel	Dc to 4	6 <sup>4</sup>	≤0.15
		4 to 8		≤0.20
		8 to 18		≤0.25
1506A	Weinschel	Dc to 18	6 dB, -0.2, +1.2 dB max to 10.0 GHz; +1.5 dB max to 18.0 GHz	
		Dc to 4		±0.2
		4 to 10		±0.4
		10 to 18		±0.5
1870A <sup>3</sup>	Weinschel	Dc to 18	6 dB +1.5	
		Dc to 8		±0.15
		8 to 18		±0.2
11667A	Hewlett-Packard	Dc to 4	6 <sup>4</sup>	≤0.15
		4 to 8		≤0.20
		8 to 18		≤0.25
11667B <sup>3</sup>	Hewlett-Packard	Dc to 26.5	6 <sup>4</sup>	
		Dc to 18		≤0.25
		18 to 26.5		≤0.40

<sup>1</sup>Not checked below 10 MHz.

<sup>2</sup>Between output ports.

<sup>3</sup>Attach test report for the frequencies requested or required by customer.

<sup>4</sup>Value determined in calibration process.



**APPENDIX E  
ALTERNATE CALIBRATION PROCESS  
FOR DIRECTIONAL COUPLERS (10MHZ TO 18GHZ)**

**NOTE**

Software package USATA PD-MAT () can be used in place of steps **1 a** (1) through **1 a** (35) below, verifying that the TI meets or exceeds accuracies listed in Appendix A. Copies of the software package are available from Commander, U. S. Army Aviation and Missile Life Cycle Management Command, ATTN: AMSAM-TMD-LW, Redstone Arsenal, AL 35898-5000 or on the USATA homepage.

**1. Alternate Calibration Process for Directional Couplers (10 MHz to 18 GHz)**

**a. Performance Check**

**NOTE**

When performing the following steps if TI frequency range is above and below 1.3 GHz it will be necessary to perform two separate tests - one below and one above 1.3 GHz.

- (1) Zero and calibrate power meter and measuring receiver RF power.
- (2) Connect equipment as shown in figure 7 (Connect POINT A to POINT B). Determine and record in table E-1 a minimum of 10 evenly spaced test frequencies over the entire TI frequency range.
- (3) Adjust signal generator No. 1 frequency controls to test frequency recorded in table E1 and adjust signal generator No. 1 **RF OUTPUT** controls for +6 dBm.

**NOTE**

Use adapters as needed.

- (4) Press **4.0 SPCL** keys and, if the **AUTO TUNING** indicator light is off, press the measuring receiver **FREQ** and **BLUE (SHIFT) AUTO TUNING** keys.

**NOTE**

For frequencies below 1.3 GHz proceed to step (8).

**NOTE**

For frequencies 1.3 GHz and above, proceed to step (5) below.  
For frequencies above 1.3 GHz, the offset frequency should be 120.53 MHz above that of signal generator No. 1.

- (5) Enter the test frequency into the measuring receiver and press the **MHz** key.
- (6) Calculate and record the proper offset frequency and record it as the Offset Frequency in table E1 alongside the appropriate test frequency. Set signal generator No. 2 to produce a +8 dB output at offset frequency.

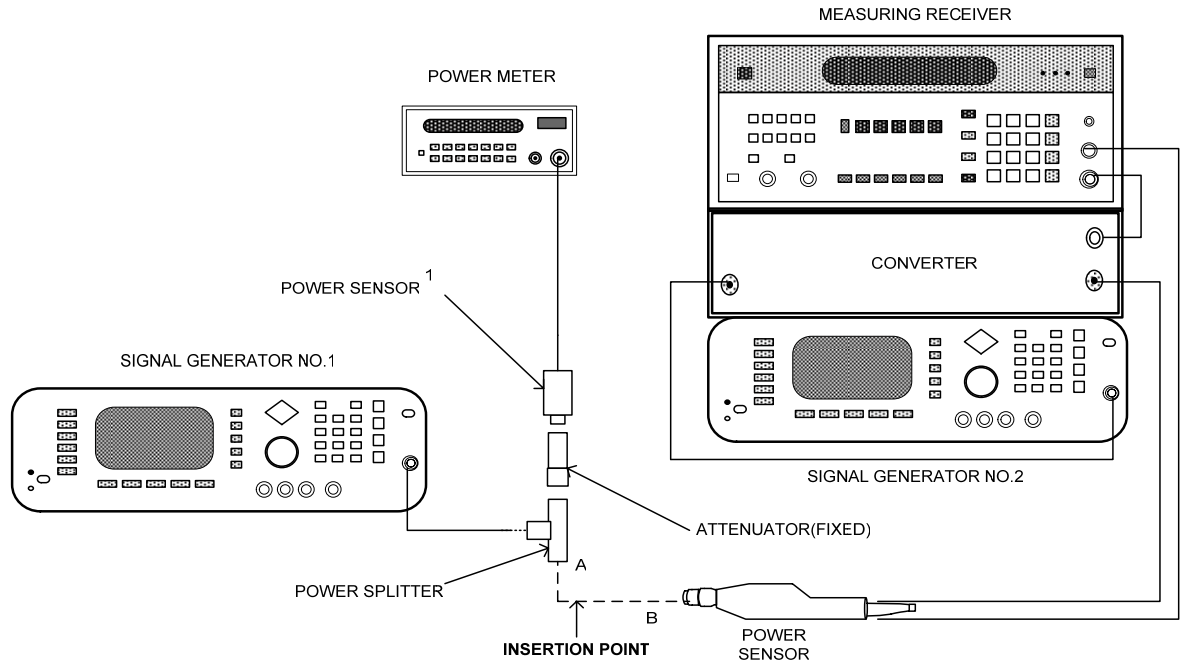

<sup>1</sup>For frequencies below 50 MHz use power sensor 8482A and a 10 dB attenuator and for frequencies above 50 MHz use power sensor 8485D and a 30 dB attenuator.

Figure 7. Alternate Equipment Setup (10 MHz to 18 GHz).

Table E1

Test frequency	Offset frequency	Power meter reading	Init dB reading	First cal point	Second cal point	First RF cal fac (%)	Second RF cal fac (%)	Set ref cal fac (%)

(7) Press measuring receiver **27.3 SPCL** keys, enter the offset frequency from table E1, and press the **MHz** key.

(8) Press the **GOLD (S) TUNED RF LEVEL, 39.9, SPCL, 3.7 SPCL, and 1.9 SPCL** keys then press the **LOG/LIN** key for dBm units.

(9) Note the power meter reading and record it as power meter reading in table E1 alongside the appropriate test frequency.

(10) Note the measuring receiver reading and record it as Init dB reading in table E1 alongside the appropriate test frequency.

(11) Press the **TI BLUE (SHIFT)** key, then the **SET REF (ZERO)** key.

(12) Calculate the first cal point using the formula  $-40 + \text{signal generator No. 1 (No.2) output level} - \text{Init dB reading}$ . (Example  $-40 \text{ dBm} + (6 \text{ dBm}) - (-1 \text{ dBm}) = -33 \text{ dBm}$ ). Record this value, as first cal point in table B1 alongside the appropriate test frequency.

(13) Set signal generator No. 1 to the level calculated in (12) above and press the **CALIBRATE** key.

(14) Calculate the second cal point using the formula  $-80 + \text{signal generator No. 1 output level} - 40 \text{ dBm}$  to result of step (12). (Example  $-80 \text{ dBm} + (6 \text{ dBm}) - (-1 \text{ dBm}) = -73 \text{ dBm}$ ). Record this value, as second cal point in table E1 alongside the appropriate test frequency.

(15) Set signal generator No. 1 to the level calculated in (14) above and press the **CALIBRATE** key.

(16) Set signal generator No. 1 to the initial level of +6 dBm.

(17) Press **38.2** and **SPCL** keys and record the displayed value as First RF cal fac in table E1 alongside the appropriate test frequency.

(18) Press **38.3** and **SPCL** keys and record the displayed value as Second RF cal fac in table E1 alongside the appropriate test frequency.

(19) Press **38.4** and **SPCL** keys and record the displayed value as Set Ref cal fac in table E1 alongside the appropriate test frequency.

(20) Repeat steps (3) through (19) for each of the test frequencies in table E1.

(21) Press the **FREQ** and **BLUE (SHIFT) AUTO TUNING** keys.

(22) Set signal generator No. 1 to appropriate test frequency listed in table E1.

(23) Press the **GOLD(S) TUNED RF LEVEL, 26.1** and **SPCL** keys.

#### NOTE

For frequencies below 1.3 GHz proceed to step (26) below.

(24) Press **27.3 SPCL**, enter the appropriate offset frequency from table B1, and press the **MHz** key. (Ignore the displayed frequency reading.)

(25) Set signal generator No. 2 for an output of +8 dBm and the appropriate offset frequency from table E1.

(26) Connect TI into figure 7 equipment setup as listed in (a) through (d) below:

**TB 9-5985-314-35**

- (a) **INPUT PORT** to POINT A.
- (b) **SIDEARM PORT** to POINT B.
- (c) **OUTPUT PORT** to 50  $\Omega$  termination.
- (d) **AUX (TEST) SIDE ARM PORT** (if any) to 50  $\Omega$  termination.

(27) Adjust signal generator No. 1 for a power meter indication as recorded in table E1 as Power meter reading.

(28) Press **39.2 SPCL** and enter the First RF Cal Fac from table E1 for the appropriate frequency, and press the **BLUE (SHIFT) % CAL FACTOR (MHz)** keys.

(29) Press **39.3 SPCL** and enter the Second RF Cal Fac from table E1 for the appropriate frequency, and press the **BLUE (SHIFT) % CAL FACTOR (MHz)** keys.

(30) Press **39.4 SPCL**, enter the Set ref cal fac from table E1 for the appropriate frequency, and press the **BLUE (SHIFT) % CAL FACTOR (MHz)** keys.

(31) Record measuring receiver indication. Measuring Receiver indication will be within the nominal coupling value  $\pm$  (coupling variation) + ( $\pm$  frequency sensitivity) tolerances listed for TI in Appendix A.

(32) Repeat steps (21) through (25) and (27) through (31) above for remaining test frequencies recorded in table E1.

(33) Repeat steps (21) through (30). Replace step (26) with the following:

Connect TI into figure 7 equipment setup as listed in (a) through (d) below:

- (a) **OUTPUT PORT** to POINT A.
- (b) **SIDEARM PORT** to POINT B.
- (c) **INPUT PORT** to 50  $\Omega$  termination.
- (d) **AUX (TEST) SIDEARM PORT** (if any) to 50  $\Omega$  termination.

(34) Record measuring receiver indication. Measuring receiver indication will be greater than or equal to the value listed in TI directivity column, Appendix A.

(35) Repeat steps (21) through (25) and (27) through (30). Measuring receiver indication will be greater than or equal to the value listed in TI directivity column, Appendix A.

**b. Adjustment.** No adjustments can be made; however, a correction chart may be prepared listing actual coupling and directivity values at test frequencies.

**NOTE**

When determining directivity, in- or out-of-tolerance condition, all of the below must be considered:

1. Termination mismatch errors can cause measured directivity to appear slightly lower than normal.
2. A 10 percent variation in directivity is acceptable for most directional couplers used in direct support of field activities in the U. S. Army.
3. A directional coupler may be out of tolerance at a specific frequency and still be useable over the rest of its range.

**2. Final Procedure**

- a. Deenergize and disconnect all equipment.
- b. Annotate and affix DA label/form in accordance with TB 750-25.





**APPENDIX F  
ALTERNATE CALIBRATION PROCESS  
FOR VSWR BRIDGES (10MHZ TO 18GHZ)**

**NOTE**

Software package USATA PD-MAT () can be used in place of steps **1 a** (1) through **1 a** (36) below, verifying that the TI meets or exceeds accuracies listed in Appendix B. Copies of the software package are available from Commander, U. S. Army Aviation and Missile Command, ATTN: AMSAM-TMD-LW, Redstone Arsenal, AL 35898-5000.

**1. Alternate Calibration Process for VSWR Bridges (10 MHz to 18 GHz)**

**a. Performance Check**

**NOTE**

When performing the following steps, if TI frequency range above and below 1.3 GHz, it will be necessary to perform two separate tests - one below and one above 1.3 GHz.

(1) Zero and calibrate power meter and measuring receiver RF power. Connect TI as shown in figure 7, Appendix E.

(2) Determine and record in Table F-1 a minimum of 10 evenly spaced test frequencies over the entire TI frequency range. Connect N-Short to TI **DEVICE UNDER TEST** port.

(3) Adjust signal generator No. 1 frequency controls to test frequency recorded in table F1 and adjust signal generator No. 1 **RF OUTPUT** controls for +6 dBm.

**NOTE**

Use adapters as needed.

(4) Press **4.0 SPCL** keys and, if the **AUTO TUNING** indicator light is off, press the measuring receiver **FREQ** and **BLUE (SHIFT) AUTO TUNING** keys.

**NOTE**

For frequencies below 1.3 GHz proceed to step (8).

**NOTE**

For frequencies 1.3 GHz and above, proceed to step (5) below. For frequencies above 1.3 GHz, the offset frequency should be 120.53 MHz above that of signal generator No. 1.

(5) Enter the test frequency into the measuring receiver and press the **MHz** key.

**TB 9-5985-314-35**

(6) Calculate and record the proper offset frequency and record it as the Offset frequency in table F1 alongside the appropriate test frequency. Set signal generator No. 2 to produce a +8 dB output at offset frequency.

Table F1

Test frequency	Offset frequency	Power meter reading	Init dB reading	First cal point	Second cal point	First RF cal fac (%)	Second RF cal fac (%)	Set ref cal fac (%)

(7) Press measuring receiver **27.3 SPCL** keys, enter the offset frequency from table F1, and press the **MHz** key.

(8) Press the **GOLD (S) TUNED RF LEVEL, 39.9, SPCL, 3.7 SPCL,** and **1.9 SPCL** keys then press the **LOG/LIN** key for dBm units.

(9) Note the power meter reading and record it as Power meter reading in table F1 alongside the appropriate test frequency.

(10) Note the measuring receiver reading and record it as Init dB reading in table F1 alongside the appropriate test frequency.

(11) Press the **TI BLUE (SHIFT)** key, then the **SET REF (ZERO)** key.

(12) Calculate the first cal point using the formula  $-40 + \text{signal generator No. 1 output level} - \text{Init dB reading}$ . (Example  $-40 \text{ dBm} + (6 \text{ dBm}) - (-1 \text{ dBm}) = -33 \text{ dBm}$ ). Record this value, as First cal point in table F1 alongside the appropriate test frequency.

(13) Set signal generator No. 1 to the level calculated in (12) above and press the **CALIBRATE** key.

(14) Calculate the second cal point using the formula  $-80 + \text{signal generator No. 1 output level} - 40 \text{ dBm}$  to result of step (12). (Example  $-80 \text{ dBm} + (6 \text{ dBm}) - (-1 \text{ dBm}) = -73 \text{ dBm}$ ). Record this value, as Second cal point in table F1 alongside the appropriate test frequency.

- (15) Set signal generator No. 1 to the level calculated in (14) above and press the **CALIBRATE** key.
- (16) Set signal generator No. 1 to the initial level of +6 dBm.
- (17) Press **38.2** and **SPCL** keys and record the displayed value as First RF cal fac in table F1 alongside the appropriate test frequency.
- (18) Press **38.3** and **SPCL** keys and record the displayed value as Second RF cal fac in table F1 alongside the appropriate test frequency.
- (19) Press **38.4** and **SPCL** keys and record the displayed value as Set RF cal fac in table F1 alongside the appropriate test frequency.
- (20) Repeat steps (3) through (19) for each of the test frequencies in table F1.
- (21) Press the **FREQ** and **BLUE (SHIFT) AUTO TUNING** keys.
- (22) Set signal generator No. 1 to appropriate test frequency listed in table F1.
- (23) Press the **GOLD(S) TUNED RF LEVEL, 26.1** and **SPCL** keys.

**NOTE**

For frequencies below 1.3 GHz proceed to step (26) below.

- (24) Press **27.3 SPCL**, enter the appropriate offset frequency from table F1, and press the **MHz** key. (Ignore the displayed frequency reading.)
- (25) Set signal generator No. 2 for an output of +8 dBm and the appropriate offset frequency from table F1.
- (26) Remove N-short from TI.
- (27) Connect mismatch as listed in table F2 to **TI DEVICE UNDER TEST** port.
- (28) Adjust signal generator No. 1 for a power meter indication as recorded in table F1 as Power meter reading.
- (29) Press **39.2 SPCL** and enter the First RF cal fac from table F1 for the appropriate frequency, and press the **BLUE (SHIFT) % CAL FACTOR (MHz)** keys.
- (30) Press **39.3 SPCL** and enter the Second RF cal fac from table F1 for the appropriate frequency, and press the **BLUE (SHIFT) % CAL FACTOR (MHz)** keys.
- (31) Press **39.4 SPCL**, enter the Set Ref cal fac from table F1 for the appropriate frequency, and press the **BLUE (SHIFT) % CAL FACTOR (MHz)** keys.
- (32) Record measuring receiver indication in table F2.

Table F2. Return Loss Measurements (with N-Short)

Test frequency	Mismatch 2334-001-1	Mismatch 2334-001-2	Mismatch 2334-001-3	Mismatch 2334-001-4

(33) Repeat steps (21) through (25) and (27) through (32) with remaining mismatches.

(34) Repeat steps (3) through (31). Note: Initial reference will be run with **DEVICE UNDER TEST** port open.

(35) Record Measuring Receiver indication in table F3.

Table F3. Return Loss Measurements (without N-Short)

Test frequency	Mismatch 2334-001-1	Mismatch 2334-001-2	Mismatch 2334-001-3	Mismatch 2334-001-4

(36) Add readings from table F2 and table F3 then divide by 2. Return loss in dB indication will be within the limits specified in table 2 (for secondary reference as stated in test report plus or minus specifications of SWR bridges).

**2. Final Procedure**

- a. Deenergize and disconnect all equipment and reinstall protective cover on TI.
- b. Annotate and affix DA label/form in accordance with TB 750-25.



**APPENDIX G  
ALTERNATE CALIBRATION PROCESS  
FOR COAXIAL CIRCULATORS (10MHZ TO 18GHZ)**

**NOTE**

Software package USATA PD-MAT () can be used in place of steps **1 a (1)** through **1 a (35)** below, verifying that the TI meets or exceeds accuracies listed in Appendix C. Copies of the software package are available from Commander, U. S. Army Aviation and Missile Command, ATTN: AMSAM-TMD-LW, Redstone Arsenal, AL 35898-5000.

**1. Alternate Calibration Process for Coaxial Circulators**

**a. Performance Check**

- (1) Zero and calibrate power meter and measuring receiver RF power, then connect equipment as shown in figure 7, Appendix E (Connect POINT A to POINT B).
- (2) Adjust signal generator No. 1 to 0.960 Ghz and **RF OUTPUT** controls for +6 dBm.
- (3) Press **4.0 SPCL** keys and if the **AUTO TUNING** indicator light is off press the measuring receiver **FREQ** and **BLUE(SHIFT) AUTO TUNING** keys.
- (4) Press the **GOLD (S) TUNED RF LEVEL, 39.9, SPCL, 3.7 SPCL,** and **1.9 SPCL** keys then press the **LOG/LIN** key for dBm units.

Table G1

Test Frequency GHz	Power meter reading	Init dB reading	First cal point	Second cal point	First RF cal fac (%)	Second RF cal fac (%)	Set ref cal fac (%)
0.960							
1.000							
1.030							
1.060							
1.090							
1.100							

- (5) Note the power meter reading and record it as Power meter reading in table G1 alongside the appropriate test frequency.
- (6) Note the measuring receiver reading and record it as Init dB reading in table G1 alongside the appropriate test frequency.
- (7) Press the TI **BLUE (SHIFT)** key, then the **SET REF (ZERO)** key.

## TB 9-5985-314-35

(8) Calculate the first cal point using the formula  $-40 + \text{signal generator No. 1 (No.2) output level} - \text{Init dB reading}$ . (Example  $-40 \text{ dBm} + (6 \text{ dBm}) - (-1 \text{ dBm}) = -33 \text{ dBm}$ ). Record this value, as First cal point in table G1 alongside the appropriate test frequency.

(9) Set signal generator No. 1 to the level calculated in (8) above and press the **CALIBRATE** key.

(10) Calculate the second cal point using the formula  $-80 + \text{signal generator No. 1 output level} - 40 \text{ dBm}$  to result of step (8). (Example  $-80 \text{ dBm} + (6 \text{ dBm}) - (-1 \text{ dBm}) = -73 \text{ dBm}$ ). Record this value, as Second cal point in table G1 alongside the appropriate test frequency.

(11) Set signal generator No. 1 to the level calculated in (10) above and press the **CALIBRATE** key.

(12) Set signal generator No. 1 to the initial level of +6 dBm.

(13) Press **38.2** and **SPCL** keys and record the displayed value as First RF cal fac in table G1 alongside the appropriate test frequency.

(14) Press **38.3** and **SPCL** keys and record the displayed value as Second RF cal fac in table G1 alongside the appropriate test frequency.

(15) Press **38.4** and **SPCL** keys and record the displayed value as Set ref cal fac in table G1 alongside the appropriate test frequency.

(16) Repeat steps (3) through (15) for each of the test frequencies in table G1.

(17) Press the **FREQ** and **BLUE (SHIFT) AUTO TUNING** keys.

(18) Set signal generator No. 1 to appropriate test frequency listed in table G1.

(19) Press the **GOLD(S) TUNED RF LEVEL, 26.1** and **SPCL** keys.

(20) Connect TI into figure 7 equipment setup as listed in (a) through (c) below:

(a) **INPUT PORT** to POINT A.

(b) **SIDEARM PORT** to POINT B.

(c) **OUTPUT PORT** to 50  $\Omega$  termination.

(21) Adjust signal generator No. 1 for a power meter indication as recorded in table G1 as Power meter reading.

(22) Press **39.2 SPCL** and enter the First RF cal fac from table G1 for the appropriate frequency, and press the **BLUE (SHIFT) % CAL FACTOR (MHz)** keys.

(23) Press **39.3 SPCL** and enter the Second RF cal fac from table G1 for the appropriate frequency, and press the **BLUE (SHIFT) % CAL FACTOR (MHz)** keys.

(24) Press **39.4 SPCL**, enter the Set ref cal fac from table G1 for the appropriate frequency, and press the **BLUE (SHIFT) % CAL FACTOR (MHz)** keys.

(25) Measuring receiver indication will be 0.5 dB or less.

(26) Repeat steps (17) through (24) but replace step (20) with the following:



Connect TI into figure 7 equipment setup as listed in (a) through (c) below:

- (a) **OUTPUT PORT** to POINT A.
- (b) **INPUT PORT** to POINT B.
- (c) **SIDE PORT** to 50  $\Omega$  termination.

(27) Measuring receiver indication will be 20 dB or greater.

(28) Repeat steps (17) through (24) but replace step (20) with the following:

Connect TI into figure 7 equipment setup as listed in (a) through (c) below:

- (a) **OUTPUT PORT** to POINT A.
- (b) **SIDE PORT** to POINT B.
- (c) **INPUT PORT** to 50  $\Omega$  termination.

(29) Measuring receiver indication will be 0.5 dB or less.

(30) Repeat steps (17) through (24) but replace step (20) with the following:

Connect TI into figure 7 equipment setup as listed in (a) through (c) below:

- (a) **SIDE PORT** to POINT A.
- (b) **OUTPUT PORT** to POINT B.
- (c) **INPUT PORT** to 50  $\Omega$  termination.

(31) Measuring receiver indication will be 20 dB or greater.

(32) Repeat steps (17) through (24) but replace step (20) with the following:

Connect TI into figure 7 equipment setup as listed in (a) through (c) below:

- (a) **SIDE PORT** to POINT A.
- (b) **INPUT PORT** to POINT B.
- (c) **OUTPUT PORT** to 50  $\Omega$  termination.

(33) Measuring receiver indication will be 0.5 dB or less.

(34) Repeat steps (17) through (24) but replace step (20) with the following:

Connect TI into figure 7 equipment setup as listed in (a) through (c) below:

- (a) **INPUT PORT** to POINT A.
- (b) **SIDE PORT** to POINT B.

**TB 9-5985-314-35**

(c) **OUTPUT PORT** to 50  $\Omega$  termination.

(35) Measuring Receiver indication will be 20 dB or greater.

**b. Adjustment.** No adjustments can be made.

**2. Final Procedure**

**a.** Deenergize and disconnect all equipment.

**b.** Annotate and affix DA label/form in accordance with TB 750-25.

**APPENDIX H  
ALTERNATE CALIBRATION PROCESS  
FOR POWER SPLITTERS AND POWER DIVIDERS (10MHZ TO 18GHZ)**

**NOTE**

Software package USATA PD-MAT () can be used in place of steps **1 a** (1) through **1 a** (35) below, verifying that the TI meets or exceeds accuracies listed in Appendix D. Copies of the software package are available from Commander, U. S. Army Aviation and Missile Command, ATTN: AMSAM-TMD-LW, Redstone Arsenal, AL 35898-5000.

**1. Alternate Calibration Process for Power Splitters and Power Dividers (10 MHz to 18 GHz)**

**a. Performance Check**

**NOTE**

When performing the following steps, if TI frequency range above and below 1.3 GHz, it will be necessary to perform two separate tests - one below and one above 1.3 GHz.

(1) Zero and calibrate power meter and measuring receiver RF power, then connect equipment as shown in figure 7 (Connect POINT A to POINT B).

(2) Adjust signal generator No. 1 frequency controls to 10 MHz and **RF OUTPUT** controls for +6 dBm.

(3) Press **4.0 SPCL** keys and, if the **AUTO TUNING** indicator light is off, press the measuring receiver **FREQ** and **BLUE (SHIFT) AUTO TUNING** keys.

**NOTE**

For frequencies below 1.3 GHz proceed to step (7) below.

**NOTE**

For frequencies 1.3 GHz and above, proceed to step (4) below. For frequencies above 1.3 GHz, the offset frequency should be 120.53 MHz above that of signal generator No. 1.

(4) Enter the test frequency into the measuring receiver and press the **MHz** key.

(5) Calculate and record the proper offset frequency and record it as the Offset frequency in table H1 alongside the appropriate test frequency. Set signal generator No. 2 to produce a +8 dB output at offset frequency.

**TB 9-5985-314-35**

Table H1

Test frequency	Offset frequency	Power meter reading	Init dB reading	First cal point	Second cal point	First RF cal fac (%)	Second RF cal fac (%)	Set ref cal fac (%)
0.010								
0.050								
0.100								
0.280								
0.460								
0.640								
0.820								
1.000								
1.180								
1.360								
1.540								
1.720								
1.900								
2.000								
2.500								
3.000								
3.500								
4.000								
4.500								
5.000								
5.500								
6.000								
6.500								
7.000								
7.500								
8.000								
8.500								
9.000								
9.500								
10.000								
10.500								
11.000								
11.500								
12.000								
12.500								
13.000								
13.500								
14.000								

Table H1 - Continued

14.500								
15.000								
15.500								
16.000								
16.500								
17.000								
17.500								
18.000								

(6) Press measuring receiver **27.3 SPCL** keys, enter the offset frequency from table H1, and press the **MHz** key.

(7) Press the **GOLD (S) TUNED RF LEVEL, 39.9, SPCL, 3.7 SPCL,** and **1.9 SPCL** keys then press the **LOG/LIN** key for dBm units.

(8) Note the power meter reading and record it as Power meter reading in table H1 alongside the appropriate test frequency.

(9) Note the measuring receiver reading and record it as Init dB reading in table H1 alongside the appropriate test frequency.

(10) Press the **TI BLUE (SHIFT)** key, then the **SET REF (ZERO)** key.

(11) Calculate the first cal point using the formula  $-40 + \text{signal generator No.1 (No.2) output level} - \text{Init dB reading}$ . (Example  $-40 \text{ dBm} + (6 \text{ dBm}) - (-1 \text{ dBm}) = -33 \text{ dBm}$ ). Record this value, as First cal point in table H1 alongside the appropriate test frequency.

(12) Set signal generator No. 1 to the level calculated in (12) above and press the **CALIBRATE** key.

(13) Calculate the second cal point using the formula  $-80 + \text{signal generator No. 1 output level} - 40 \text{ dBm}$  to result of step (12). (Example  $-80 \text{ dBm} + (6 \text{ dBm}) - (-1 \text{ dBm}) = -73 \text{ dBm}$ ). Record this value, as Second cal point in table H1 alongside the appropriate test frequency.

(14) Set signal generator No. 1 to the level calculated in (14) above and press the **CALIBRATE** key.

(15) Set signal generator No. 1 to the initial level of +6 dBm.

(16) Press **38.2** and **SPCL** keys and record the displayed value as First RF cal fac in table H1 alongside the appropriate test frequency.

(17) Press **38.3** and **SPCL** keys and record the displayed value as Second RF cal fac in table H1 alongside the appropriate test frequency.

(18) Press **38.4** and **SPCL** keys and record the displayed value as Set ref cal fac in table H1 alongside the appropriate test frequency.

(19) Repeat steps (3) through (18) for each of the test frequencies in table H1.

(20) Press the **FREQ** and **BLUE (SHIFT) AUTO TUNING** keys.

**TB 9-5985-314-35**

(21) Set signal generator No. 1 to appropriate test frequency listed in table H1.

(22) Press the **GOLD(S) TUNED RF LEVEL, 26.1** and **SPCL** keys.

**NOTE**

For frequencies below 1.3 GHz proceed to step (25) below.

(23) Press **27.3 SPCL**, enter the appropriate offset frequency from table H1, and press the **MHz** key. (Ignore the displayed frequency reading.)

(24) Set signal generator No. 2 for an output of +8 dBm and the appropriate offset frequency from table H1.

(25) Connect TI into figure 7 equipment setup as listed in (a) through (c) below:

- (a) **INPUT PORT 1** to POINT A.
- (b) **OUTPUT PORT 2** to POINT B.
- (c) **OUTPUT PORT 3** to 50  $\Omega$  termination.

(26) Adjust signal generator No. 1 for a power meter indication as recorded in table H1 as Power meter reading.

(27) Press **39.2 SPCL** and enter the First RF cal fac from table H1 for the appropriate frequency, and press the **BLUE (SHIFT) % CAL FACTOR (MHz)** keys.

(28) Press **39.3 SPCL** and enter the Second RF cal fac from table H1 for the appropriate frequency, and press the **BLUE (SHIFT) % CAL FACTOR (MHz)** keys.

(29) Press **39.4 SPCL**, enter the Set ref cal fac from table H1 for the appropriate frequency, and press the **BLUE (SHIFT) % CAL FACTOR (MHz)** keys.

(30) Record measuring receiver indication in insertion loss for **OUTPUT PORT 2** column in table H2. Insertion loss will be equal to or less than the limits listed in Appendix D.

Table H2. Insertion Loss - Output Port Tracking (10MHz to 18 GHz)

Test Frequency (GHz)	Receiver system indication Insertion loss		OUTPUT PORT TRACKING (dB)
	OUTPUT PORT 2 (dB)	OUTPUT PORT 3 (dB)	
0.010			
0.050			
0.100			
0.280			
0.460			
0.640			
0.820			
1.000			
1.180			
1.360			

Table H2. Insertion Loss - Output Port Tracking (10MHz to 18 GHz) – Continued

Test Frequency (GHz)	Receiver system indication Insertion loss		OUTPUT PORT TRACKING (dB)
	OUTPUT PORT 2 (dB)	OUTPUT PORT 3 (dB)	
1.540			
1.720			
1.900			
2.000			
2.500			
3.000			
3.500			
4.000			
4.500			
5.000			
5.500			
6.000			
6.500			
7.000			
7.500			
8.000			
8.500			
9.000			
9.500			
10.000			
10.500			
11.000			
11.500			
12.000			
12.500			
13.000			
13.500			
14.000			
14.500			
15.000			
15.500			
16.000			
16.500			
17.000			
17.500			
18.000			

(31) Repeat steps (20) through (24) and (26) through (30) for remaining frequencies in table H1.

(32) Repeat steps (21) through (30). Replace step (25) with the following:

**TB 9-5985-314-35**

Connect TI into figure 7 equipment setup as listed in (a) through (c) below:

- (a) **INPUT PORT 1** to POINT A.
- (b) **OUTPUT PORT 2** to 50Ω termination.
- (c) **OUTPUT PORT 3** to POINT B.

(33) Record measuring receiver indication in insertion loss for **OUTPUT PORT 3** column in table H2. Insertion loss will be equal to or less than the limits listed in Appendix D.

(34) Repeat steps (20) through (24) and (26) through (30) for remaining frequencies in Table H1. Record measuring receiver indication in insertion loss for **OUTPUT PORT 3** column in table H2. Insertion loss will be equal to or less than the limits listed in Appendix D.

(35) Algebraically calculate the difference between the values recorded for **OUTPUT PORT 2** and **OUTPUT PORT 3** in table H2. Record results in **OUTPUT PORT TRACKING** column in table H2. Output port tracking will be within the limits specified in Appendix D.

**b. Adjustment.** Prepare a chart (if required) similar to table H2 for TI frequency range.

**2. Final Procedure**

- a.** Deenergize and disconnect all equipment.
- b.** Annotate and affix DA label/form in accordance with TB 750-25.



By Order of the Secretary of the

Official



JOYCE E. MORROW  
*Administrative Assistant to the  
Secretary of the Army*

0605905

PETER J. SCHOOMAKER  
*General, United States Army  
Chief of Staff*

Distribution:

To be distributed in accordance with the initial distribution number (IDN) 342085, requirements for calibration procedure TB 9-5985-314-35.



## Instructions for Submitting an Electronic 2028

The following format must be used if submitting an electronic 2028. The subject line must be exactly the same and all fields must be included; however, only the following fields are mandatory: 1, 3, 4, 5, 6, 7, 8, 9, 10, 13, 15, 16, 17, and 27.

From: "Whomever" [whomever@redstone.army.mil](mailto:whomever@redstone.army.mil)

To: <2028@redstone.army.mil

Subject: DA Form 2028

1. **From:** Joe Smith
2. **Unit:** home
3. **Address:** 4300 Park
4. **City:** Hometown
5. **St:** MO
6. **Zip:** 77777
7. **Date Sent:** 19-OCT -93
8. **Pub no:** 55-2840-229-23
9. **Pub Title:** TM
10. **Publication Date:** 04-JUL-85
11. **Change Number:** 7
12. **Submitter Rank:** MSG
13. **Submitter FName:** Joe
14. **Submitter MName:** T
15. **Submitter LName:** Smith
16. **Submitter Phone:** 123-123-1234
17. **Problem:** 1
18. **Page:** 2
19. **Paragraph:** 3
20. **Line:** 4
21. **NSN:** 5
22. **Reference:** 6
23. **Figure:** 7
24. **Table:** 8
25. **Item:** 9
26. **Total:** 123
27. **Text**

This is the text for the problem below line 27.





